

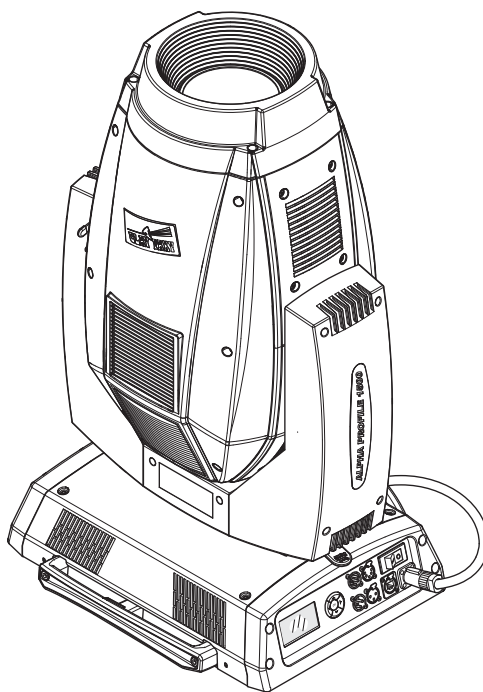

INSTRUCTION MANUAL



INDEX

Pag.	Contents
2	Safety information
3	Unpacking and preparation
4	Installation and start-up
5	Control panel
7	Menu setting
16	Maintenance
24	Technical information
24	Cause and solution of problems
25	Channel functions

Congratulations on choosing a Clay Paky product!

We thank you for your custom.

Please note that this product, as all the others in the rich Clay Paky range, has been designed and made with total quality to ensure excellent performance and best meet your expectations and requirements.

Carefully read this instruction manual in its entirety and keep it safe for future reference. It is essential to know the information and comply with the instructions given in this manual to ensure the fitting is installed, used and serviced correctly and safely.

CLAY PAKY S.p.A. disclaims all liability for damage to the fitting or to other property or persons deriving from installation, use and maintenance that have not been carried out in conformity with this instruction manual, which must always accompany the fitting.

CLAY PAKY S.p.A. reserves the right to modify the characteristics stated in this instruction manual at any time and without prior notice.

SAFETY INFORMATION

• Installation

Make sure all parts for fixing the projector are in a good state of repair.
Make sure the point of anchorage is stable before positioning the projector.
The safety chain must be properly hooked onto the fitting and secured to the framework, so that, if the primary support system fails, the fitting falls as little as possible.
If the safety chain gets used, it needs to be replaced with a genuine spare.

• Minimum distance of illuminated objects

The projector needs to be positioned so that the objects hit by the beam of light are at least 5 metres (16'5") from the lens of the projector.

• Minimum distance from flammable materials

The projector must be positioned so that any flammable materials are at least 0.20 metres (8") from every point on the surface of the fitting.

• Mounting surfaces

It is permissible to mount the fitting on normally flammable surfaces.

• Maximum ambient temperature

Do not operate the fixture if the ambient temperature (T_a) exceeds 40° C (104° F).

• IP20 protection rating

The fitting is protected against penetration by solid bodies of over 12mm (0.47") in diameter (first digit 2), but not against dripping water, rain, splashes or jets of water (second digit 0).

• Protection against electrical shock

Connection must be made to a power supply system fitted with efficient earthing (**Class I** appliance according to standard EN 60598-1).

It is, moreover, recommended to protect the supply lines of the projectors from indirect contact and/or shorting to earth by using appropriately sized residual current devices.

• Connection to mains supply

Connection to the electricity mains must be carried out by a qualified electrical installer.
Check that the mains frequency and voltage correspond to those for which the projector is designed as given on the electrical data label.
This label also gives the input power to which you need to refer to evaluate the maximum number of fittings to connect to the electricity line, in order to avoid overloading.

• Temperature of the external surface

The maximum temperature that can be reached on the external surface of the fitting, in a thermally steady state, is 150°C (302°F).

• Maintenance

Before starting any maintenance work or cleaning the projector, cut off power from the mains supply.
After switching off, do not remove any parts of the fitting for at least 10 minutes. After this time the likelihood of the lamp exploding is virtually nill. If it is necessary to replace the lamp, wait for another 20 minutes to avoid getting burnt.
The fitting is designed to hold in any splinters produced by a lamp exploding. The lenses must be mounted and, if visibly damaged, they have to be replaced with genuine spares.

• Lamp

The fitting mounts a high-pressure lamp that needs an external igniter. This igniter is fitted onto the apparatus.
- Carefully read the "operating instructions" provided by the lamp manufacturer.
- Immediately replace the lamp if damaged or deformed by heat.

• Battery

This product contains a rechargeable lead-acid or lithium iron tetraphosphate battery. To preserve the environment, please dispose the battery at the end of its life according to the regulation in force.

NOT FOR RESIDENTIAL USE

The products to which this manual refers comply with the European Directives pursuant to:

- 2006/95/EC - Safety of electrical equipment supplied at low voltage (LVD)
- 2004/108/EC - Electromagnetic Compatibility (EMC)
- 2011/65/EU - Restriction of the use of certain hazardous substances (RoHS)

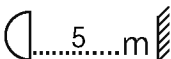
1500W 



t_a 40°C

IP20



t_c 150°C

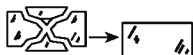

UNPACKING AND PREPARATION

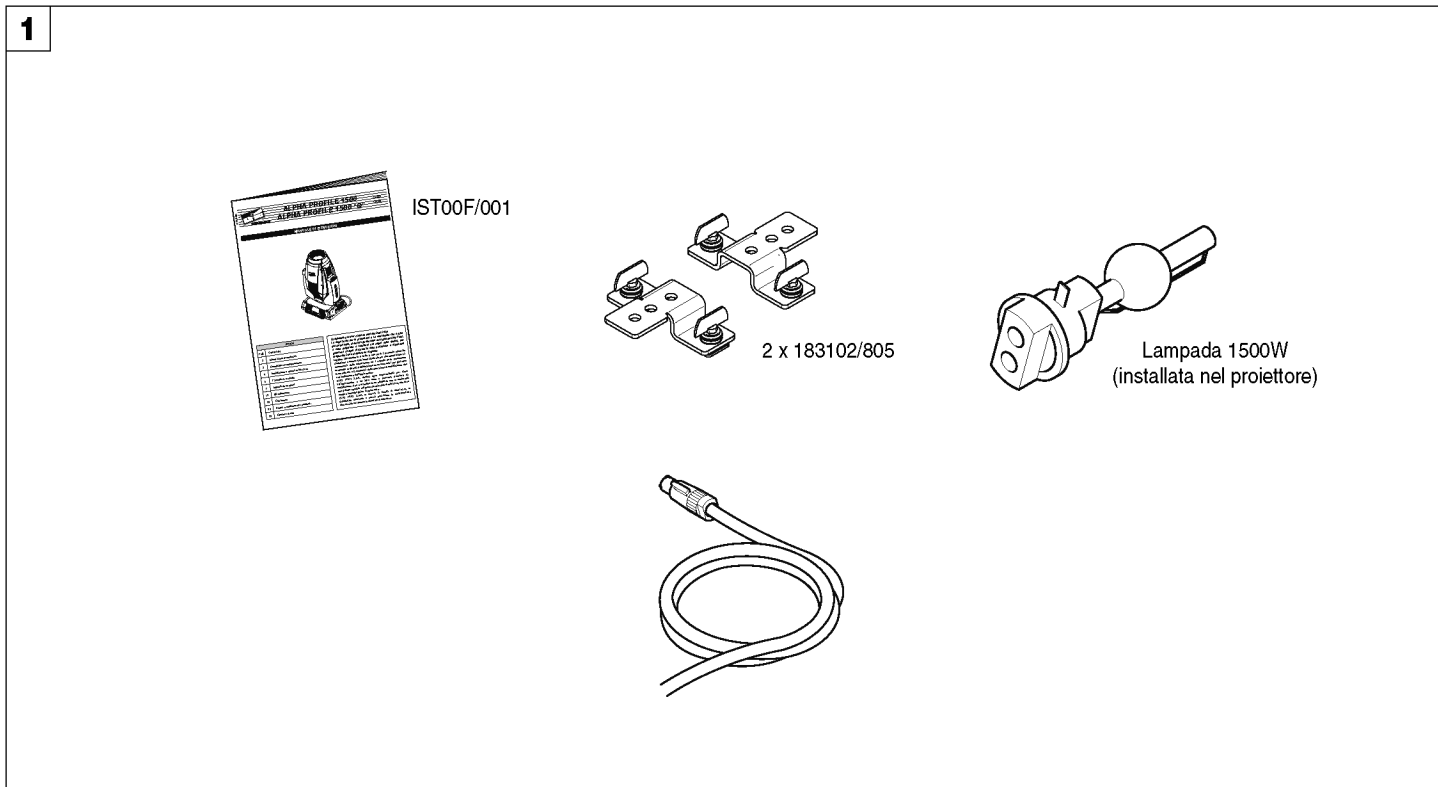

Packing contents - Fig. 1

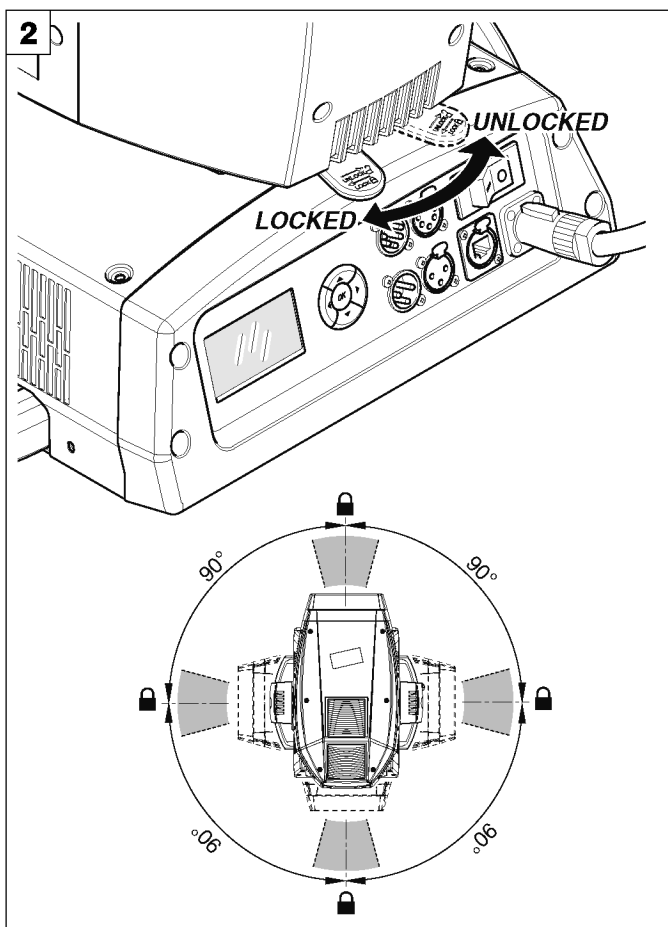

PAN Mechanism Lock and Release (every 90°) - Fig. 2

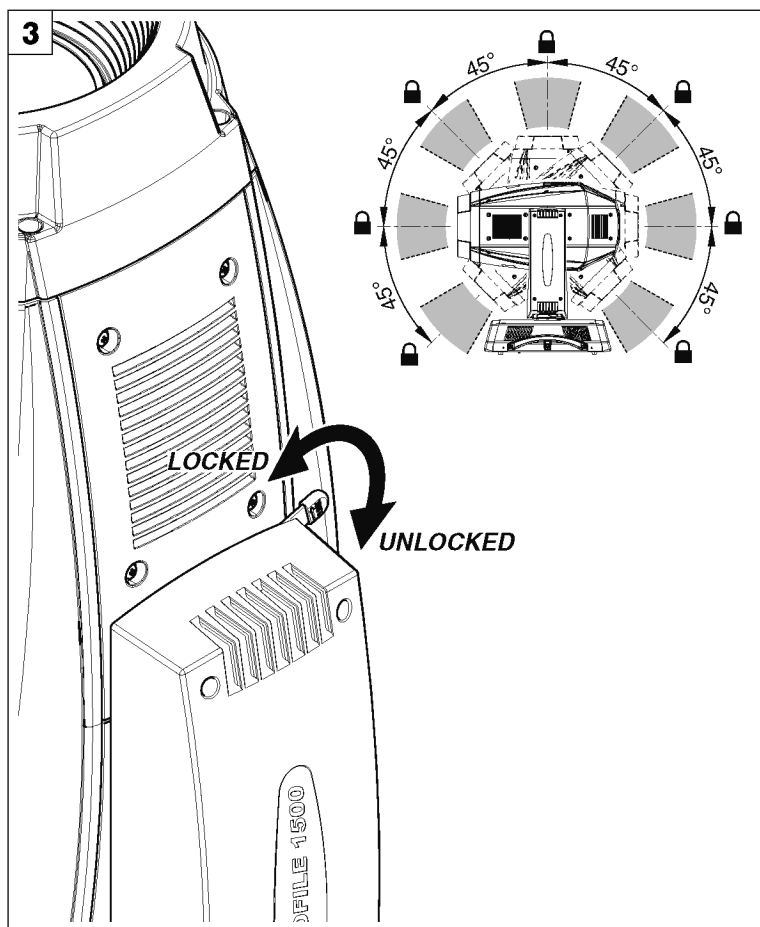

TILT Mechanism Lock and Release (every 45°) - Fig. 3

4

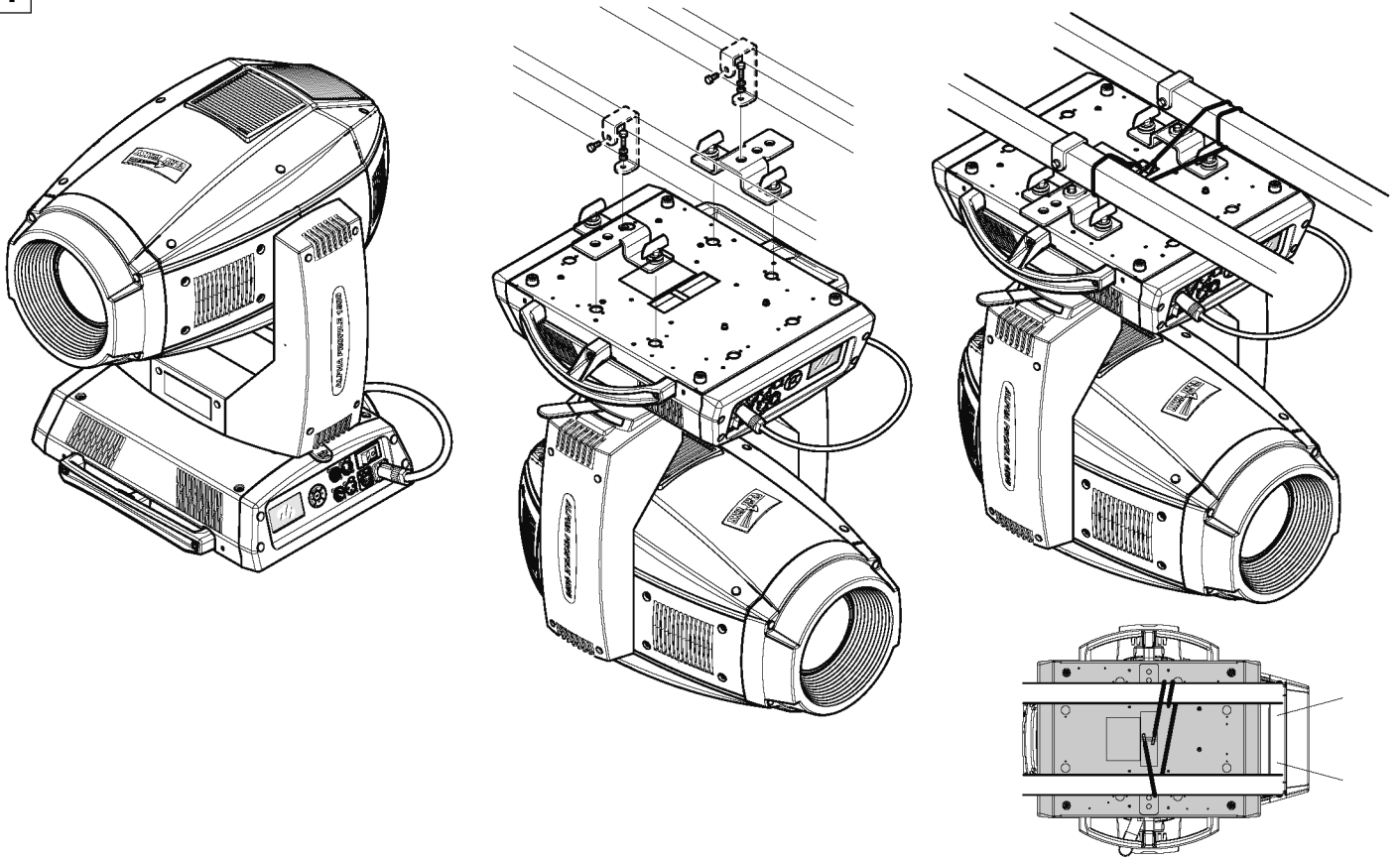

Installing the projector - Fig. 4

The projector can be installed on the floor resting on special rubber feet, on a truss or on the ceiling or wall.

WARNING: with the exception of when the projector is positioned on the floor, the safety cable must be fitted. (Cod. 105041/003 available on request). This must be securely fixed to the support structure of the projector and then connected to the fixing point at the centre of the base.

5

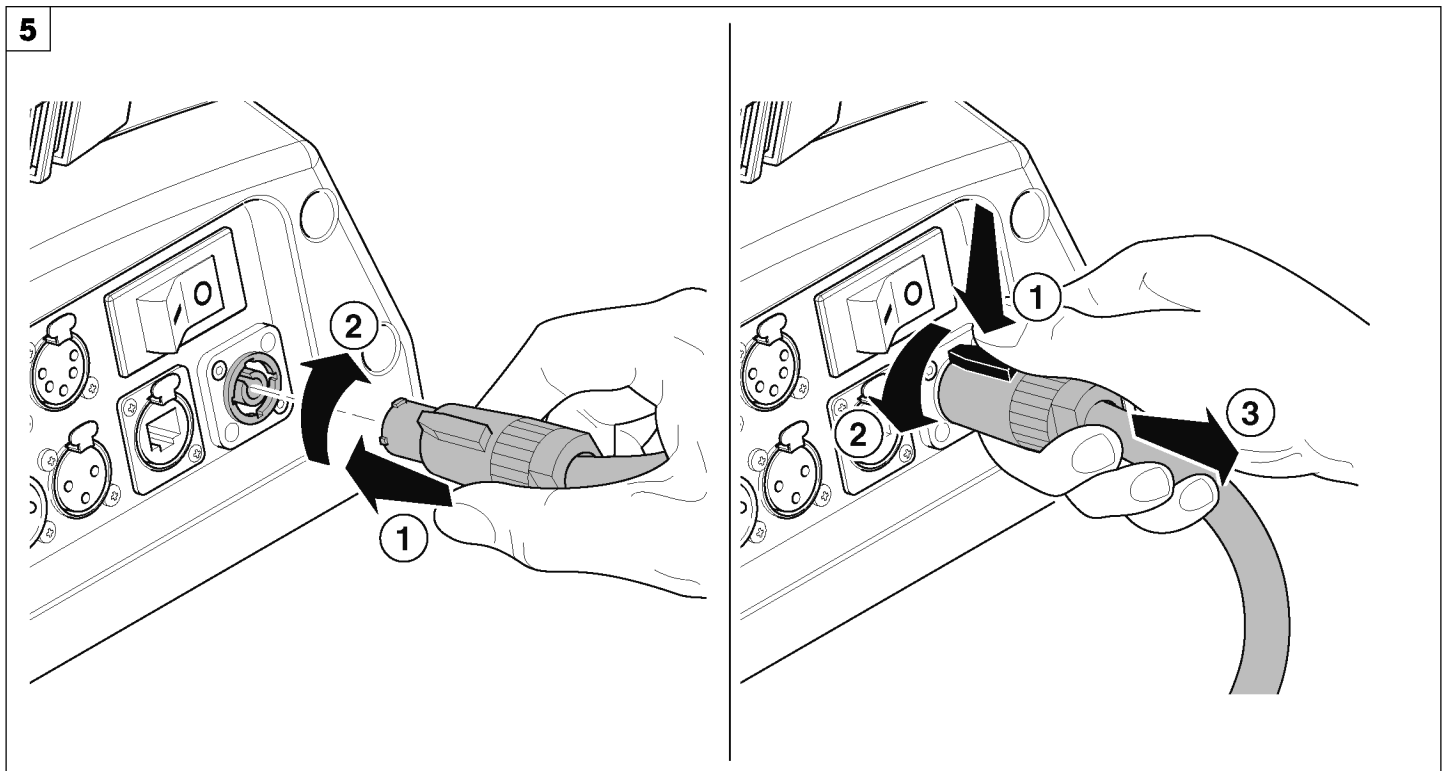

Connecting and disconnecting power cable - Fig. 5

CONTROL PANEL

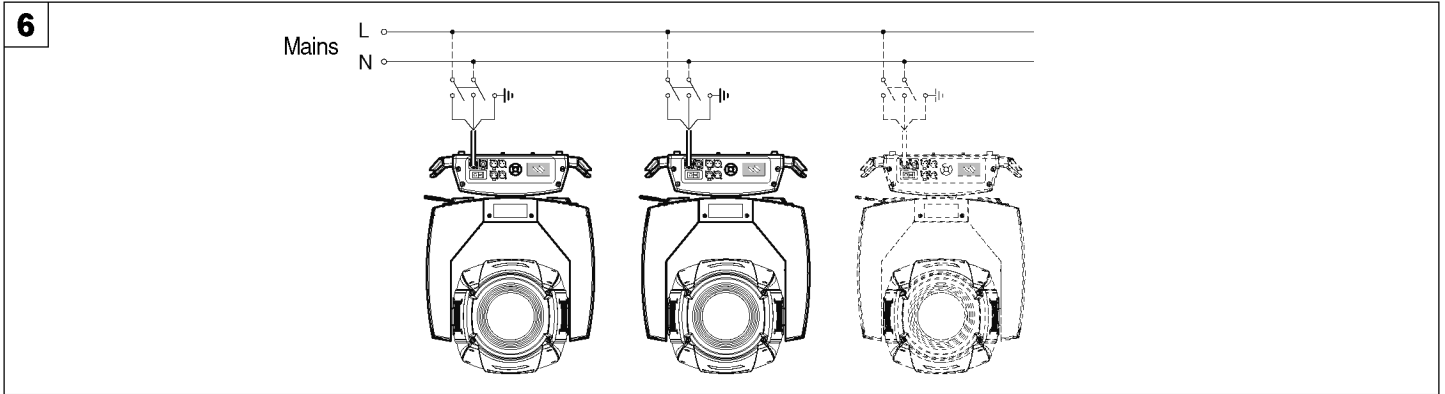

Connecting to the mains supply - Fig. 6

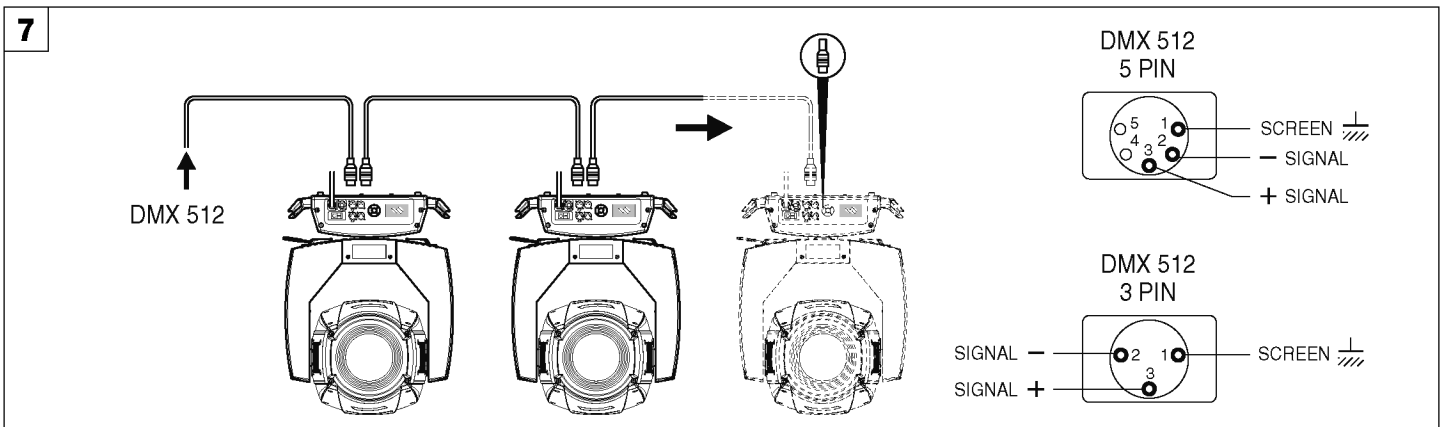

Connecting to the control signal line (DMX) - Fig. 7

Use a cable conforming to specifications EIA RS-485: 2-pole twisted, shielded, 120Ohm characteristic impedance, 22-24 AWG, low capacity. Do not use microphone cable or other cable with characteristics differing from those specified. The end connections must be made using XLR type 3 or 5-pin male/female connectors. A terminating plug must be inserted into the last projector with a resistance of 120Ohm (minimum 1/4 W) between terminals 2 and 3.

IMPORTANT: The wires must not make contact with each other or with the metal casing of the connectors. The casing itself must be connected to the shield braid and to pin 1 of the connectors.

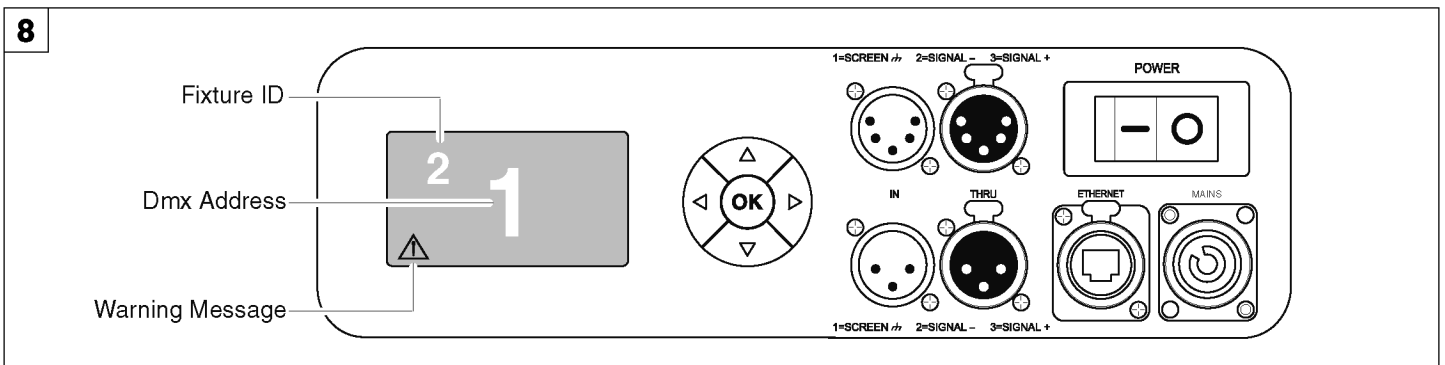

Switching on the projector - Fig. 8

Press the switch. The projector starts resetting the effects. At the same time, the following information scrolls on the display:



	Model Alpha PROFILE 1500	Firmware Version X.XX Date - Hour	xxx (Fixture ID) Dmx Address xxx	System errors E: W:
--	---------------------------------------	--	-------------------------------------	--

On conclusion of resetting in case of absence of dmx signal, Pan and Tilt move to the “Home” position (Pan 50% - Tilt 50%). The control panel (Fig. 8) has a display and buttons for the complete programming and management of the projector menu. The display can be in one of two conditions: rest status and setting status. When it is in the rest status, the display shows the projector’s DMX address and the Fixture ID address (if set).

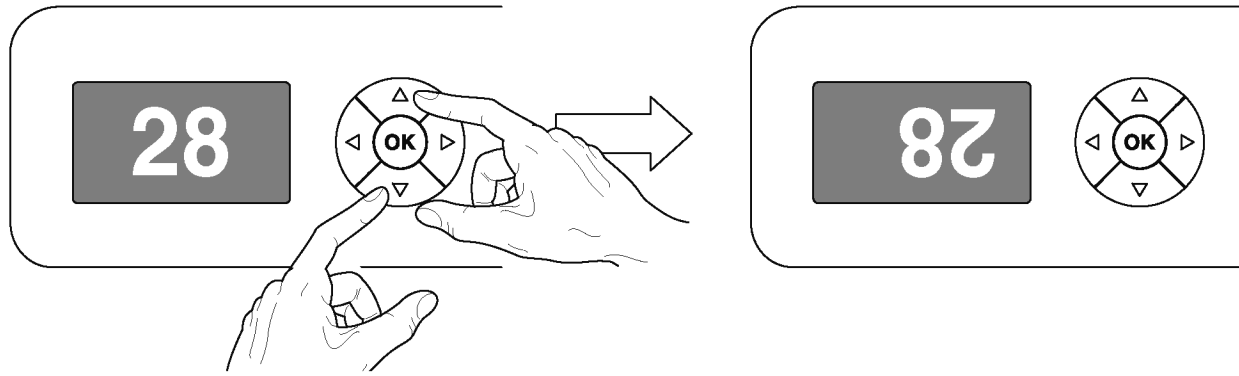
During menu setting status, after a wait time (about 30 seconds) without any key having been pressed, the display automatically returns to rest status. It should be noted that when this condition occurs, any possible value that has been modified but not yet confirmed with the **OK** key will be cancelled.



Reversal of the display - Fig. 9

To activate this function, press UP  and DOWN  keys simultaneously while the display is in the rest mode. This status will be memorised and maintained even for the next time it will be switched on. To return to the initial state, repeat the operation all over again.

Setting the projector starting address

On each projector, the starting address must be set for the control signal (addresses from 1 to 512).

The address can also be set with the projector switched off.

Setting the address: see pag. 8.

Setting the projector Fixture ID

On each projector, the Fixture ID address must be set for an easy identification of the fixtures in an installation (ID from 1 to 255).

The Fixture ID address can be set with the projector switched off.

Setting the Fixture ID: see pag. 8.

Functions of the buttons - Using the menu

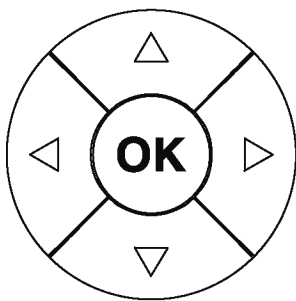

Confirms the displayed value, or activates the displayed function, or enters the successive menu.



DOWN

Decreases the value displayed (with auto-repetitions) or passes to the next item in the menu.



UP

Increases the value displayed (with auto-repetitions) or passes to the previous item in a menu.



LEFT



Return to the top level





RIGHT

Commute from units, tens, hundreds, in the "Address", "Fixture ID" and "Calibration" menu.

USING THE MENU:

- 1) Press  once – "Main Menu" appears on the display.
- 2) Use the UP  and DOWN  keys to select the menu to be used:
 - Setup (Setup Menu): To set the setting options.
 - Option (Option Menu): To set the operating options.
 - Informations (Informations Menu): To read the counters, software version and other information.
 - Manual Control (Manual control Menu): To trigger the test and manual control functions.
 - Test (Test Menu): To check the proper functioning of effects.
 - Advanced (Advanced Menu): Access to the "Advanced menu" is recommended for a trained technical personnel.

To enable the "Advanced" see pag.14
- 3) Press  to display the first item in the selected menu.
- 4) Use the UP  and DOWN  keys to select the MENU items.

Setting addresses and options with the projector disconnected

The projector's DMX address, as well as other possible operating options, can also be set when the appliance is disconnected from the electricity supply. All that is needed is to press  to momentarily activate the display and thus access the settings. Once the required operations have been carried out, the display will switch off again after a wait time of 30 seconds.

MENU SETTING

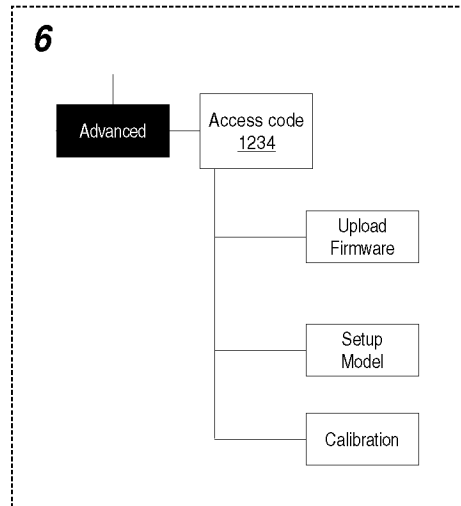
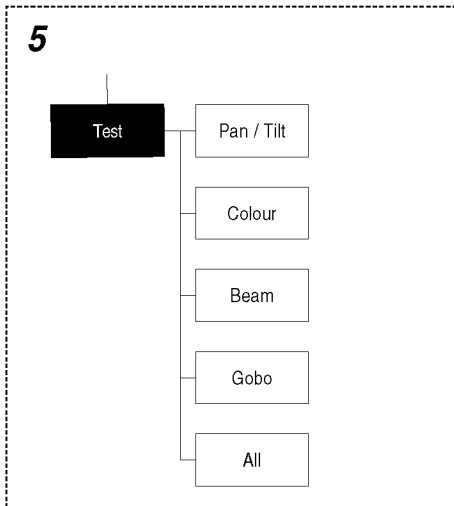
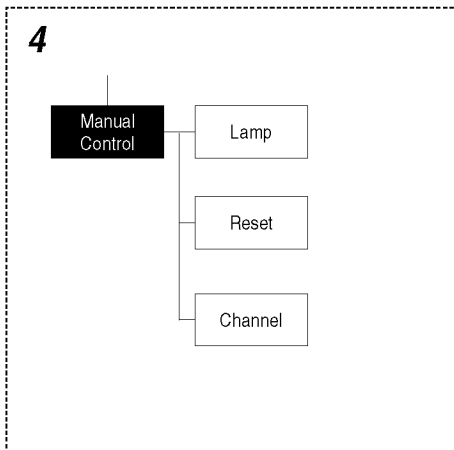
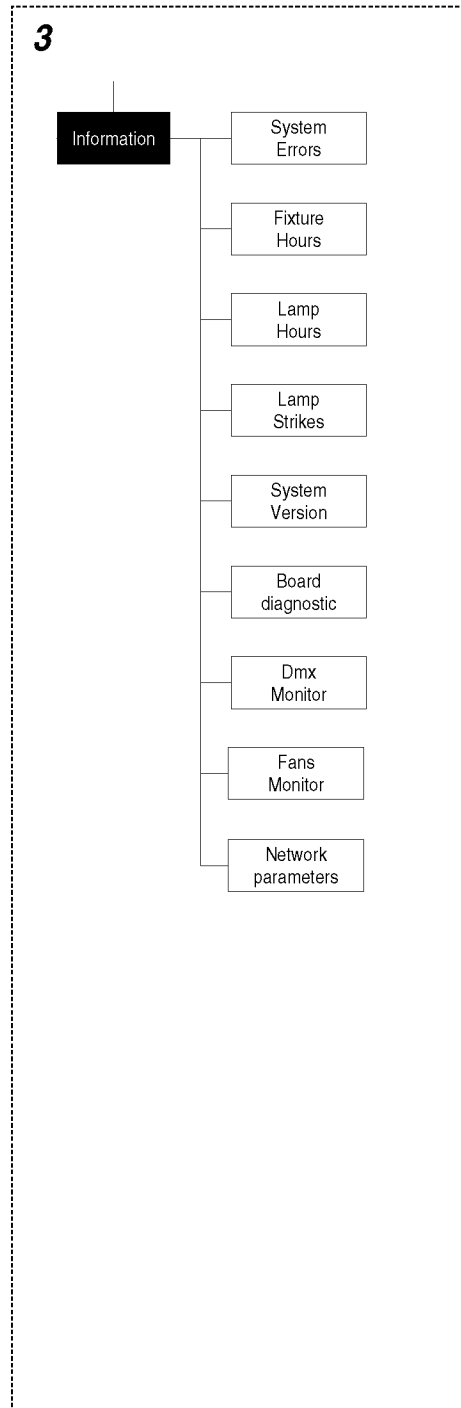
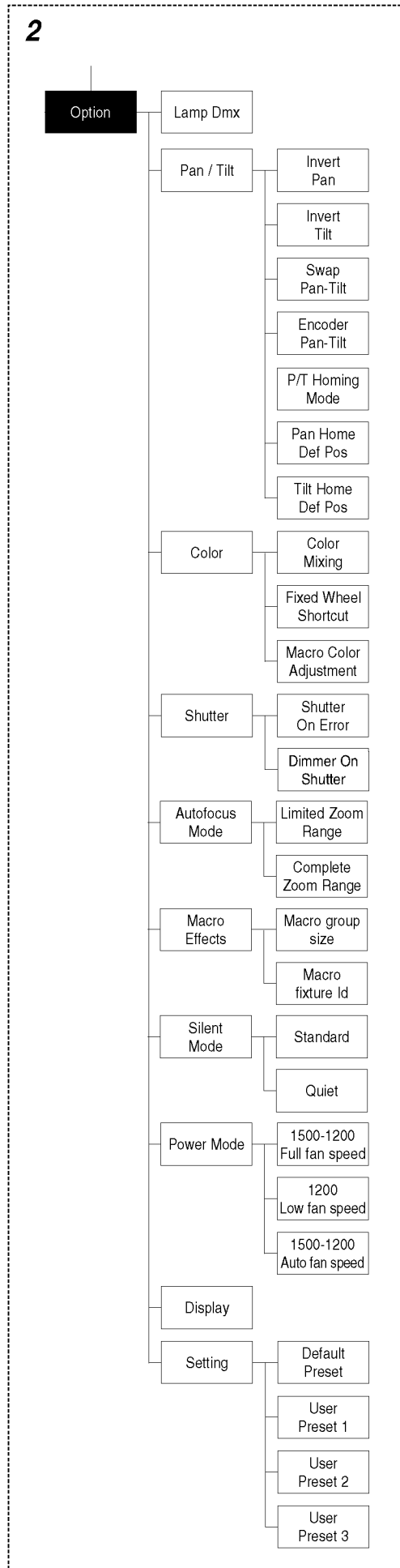
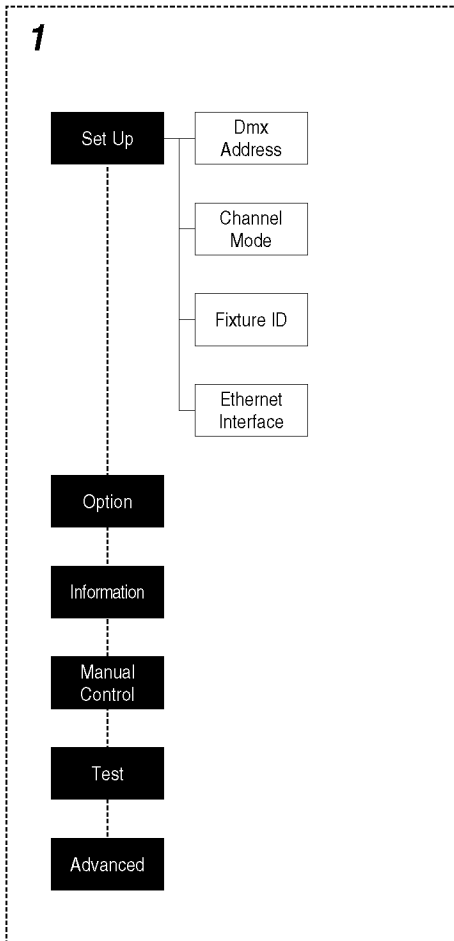

NOTE: On grey the default options

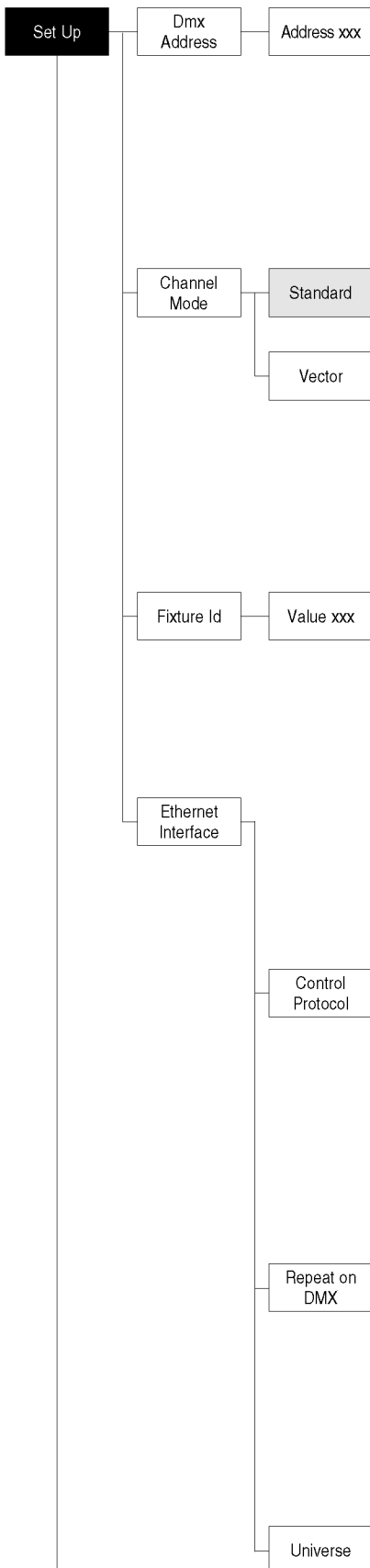

SET UP MENU

DMX ADDRESS

NOTE: without the DMX signal the Address (XXX) flashing

Allows you to select the DMX ADDRESS

- 1) Press **OK** - the current DMX Address appear on the display.
- 2) Use the UP **▲**, DOWN **▼**, RIGHT **▶** keys to plan the DMX Address.
- 3) Press **OK** to confirm the selection or LEFT **◀** to keep current settings.

CHANNEL MODE

Allows you to select a channel arrangement from the two available.

- 1) Press **OK** - the current settings appear on the display (Standard or Vector).
- 2) Use the UP **▲** and DOWN **▼** keys to select one of the following settings:
 - **Standard**
 - **Vector**
- 3) Press **OK** to confirm the selection or LEFT **◀** to keep current settings.

FIXTURE ID

Allows you to select the FIXTURE ID

- 1) Press **OK** - the current Fixture ID appear on the display.
- 2) Use the UP **▲**, DOWN **▼**, RIGHT **▶** keys to plan the Fixture ID.
- 3) Press **OK** to confirm the selection or LEFT **◀** to keep current settings.

ETHERNET INTERFACE

It lets you set the Ethernet settings to be attributed to the projector.

- 1) Press **OK**.
- 2) Use the UP **▲** and DOWN **▼** keys to select the "Ethernet Interface" options to set:

Control Protocol

It lets you select the "Control Protocol" Art-net to assign according to the control unit used:

- 1) Press **OK** the current setting appears on the display.
- 2) Use the UP **▲** and DOWN **▼** keys to select one of the following settings:
 - **Disabled**
 - **Art-net on IP 2**
 - **Art-net on IP 10**
- 3) Press **OK** to confirm the selection or LEFT **◀** to keep the current setting.

Repeat on DMX

It lets you enable the transmission of the Ethernet protocol by DMX signal to all the connected projectors.

- 1) Press **OK** the current setting appears on the display.
- 2) Use the UP **▲** and DOWN **▼** keys to select one of the following settings:
 - **Disabled:** DMX transmission disabled.
 - **Enabled on primary:** DMX transmission enabled.
- 3) Press **OK** to confirm the selection or LEFT **◀** to keep the current setting.

Universe

It lets you assign the "Universe" number to be assigned to a series of projectors.

- 1) Press **OK** - the current Universe address appears on the display.
- 2) Use the UP **▲**, DOWN **▼**, RIGHT **▶** keys to set the Universe address.
- 3) Press **OK** to confirm the selection or LEFT **◀** to keep the current setting.

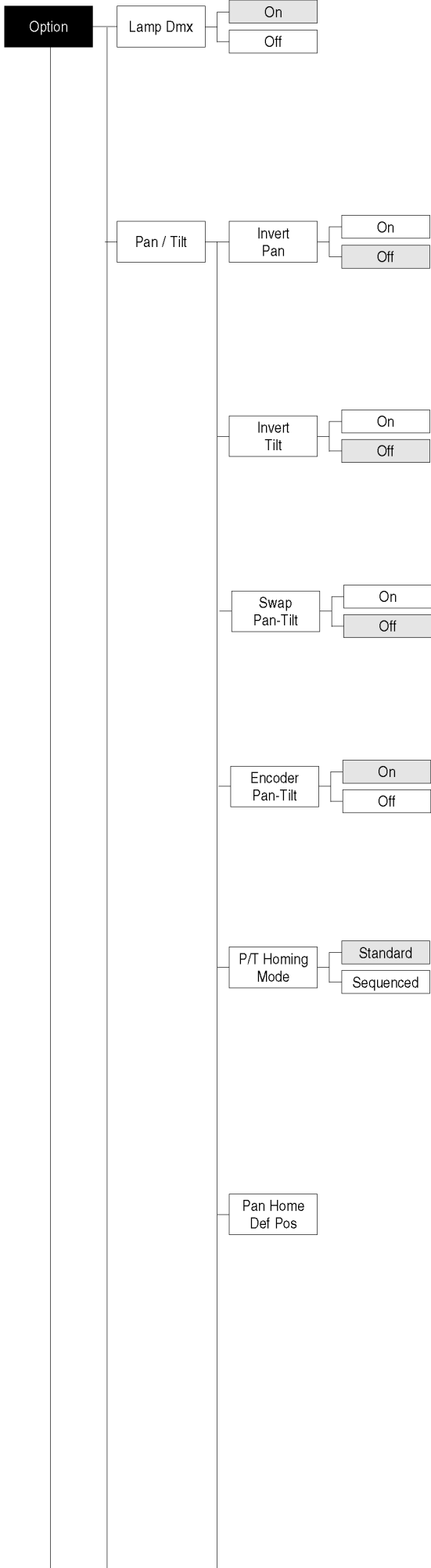

OPTIONS MENU

LAMP DMX

Used for enabling lamp remote control channel.

- 1) Press **OK** - the current settings appear on the display (On or Off).
- 2) Use the UP **▲** and DOWN **▼** keys to enable (On) or disable (Off) the lamp remote control channel.
- 3) Press **OK** to confirm the selection or LEFT **◀** to keep current settings.

PAN / TILT

Invert pan

Used for reversing Pan movement.

- 1) Press **OK** - the current settings appear on the display (On or Off).
- 2) Use the UP **▲** and DOWN **▼** keys to enable (On) or disable (Off) PAN inversion.
- 3) Press **OK** to confirm the selection or LEFT **◀** to keep current settings.

Invert tilt

Used for reversing tilt movement.

- 1) Press **OK** - the current settings appear on the display (On or Off).
- 2) Use the UP **▲** and DOWN **▼** keys to enable (On) or disable (Off) Tilt inversion.
- 3) Press **OK** to confirm the selection or LEFT **◀** to keep current settings.

Swap Pan-Tilt

Used for swapping Pan and Tilt channels (as well as Pan fine and Tilt fine).

- 1) Press **OK** - the current settings appear on the display (On or Off).
- 2) Use the UP **▲** and DOWN **▼** keys to enable (On) or disable (Off) Pan and Tilt channel swap.
- 3) Press **OK** to confirm the selection or LEFT **◀** to keep current settings.

Encoder Pan-Tilt

Used for enabling the Pan / Tilt encoders.

- 1) Press **OK** - the current settings appear on the display (On or Off).
- 2) Use the UP **▲** and DOWN **▼** keys to enable (On) or disable (Off) Pan / Tilt encoders.
- 3) Press **OK** to confirm the selection or LEFT **◀** to keep current settings.

P/T Homing Mode

Lets you set the initial projector Reset mode.

- 1) Press **OK**, the current setting appears on the display.
- 2) Use the UP **▲** and DOWN **▼** keys to select one of the following settings:
 - Standard:** Pan & Tilt are simultaneously reset.
 - Sequenced:** Tilt is reset first followed by Pan.
- 3) Press **OK** to confirm the selection or LEFT **◀** to keep the current setting.

Pan Home Def Pos

Lets you assign the Pan channel "home" position at the end of Reset, without a DMX input signal.

- 1) Press **OK**, the current setting appears on the display.
- 2) Use the UP **▲** and DOWN **▼** keys to select one of the following settings:
 - 0 degree**
 - 90 degrees**
 - 180 degrees**
 - 270 degrees (default)**
- 3) Press **OK** to confirm the selection or LEFT **◀** to keep the current setting.

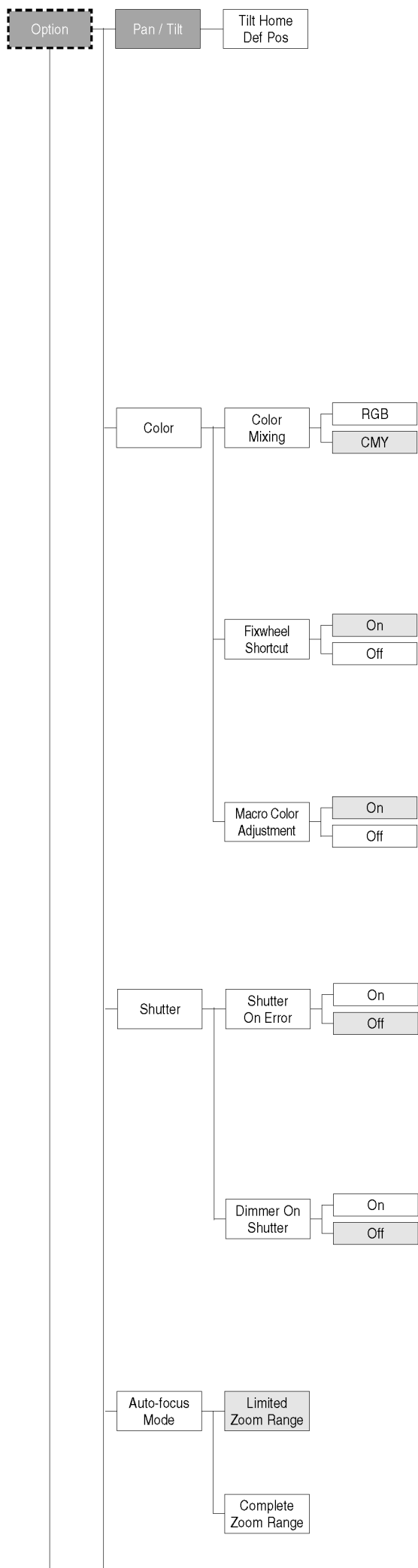

Tilt Home Def Pos

Lets you assign the Tilt channel “home” position at the end of Reset, without a DMX input signal.

- 1) Press **OK**, the current setting appears on the display.
- 2) Use the UP **▲** and DOWN **▼** keys to select one of the following settings:
 - 0%**
 - 12.5%**
 - 25%**
 - 50% (default)**
 - 75%**
 - 87.5%**
 - 100%**
- 3) Press **OK** to confirm the selection or LEFT **◀** to keep the current setting.

COLOR

Color mixing

Used for reversing the CMY color mixing system.

- 1) Press **OK** - the current settings appear on the display (On or Off).
- 2) Use the UP **▲** and DOWN **▼** keys select one of the following settings:
 - RGB color mixing mode**
 - CMY color mixing mode**
- 3) Press **OK** to confirm the selection or LEFT **◀** to keep current settings.

Fixed wheel short-cut

Used for optimizing color change time so that the disc turns in the direction that requires shorter movement.

- 1) Press **OK** – the current settings appear on the display (On or Off).
- 2) Use the UP **▲** and DOWN **▼** keys to enable (On) or disable (Off) color change optimization.
- 3) Press **OK** to confirm the selection, or LEFT **◀** to keep current settings.

Macro color adjustment

It lets you enable the overwriting of a “Macro Colour” with the Cyan, Magenta, Yellow, CTO and Colour wheel channels.

Press **OK** the current setting appears on the display.

- 1) Use the UP **▲** and DOWN **▼** keys to enable (On) or disable (Off) the overwriting.
- 2) Press **OK** to confirm the selection or LEFT **◀** to keep the current setting.

SHUTTER

Shutter on error

Used for automatically closing the stop/strobe in the event of Pan/Tilt position error.

- 1) Press **OK** - the current settings appear on the display (On or Off).
- 2) Use the UP **▲** and DOWN **▼** keys to enable (On) or disable (Off) automatic stop/strobe closing in the event of Pan/Tilt position error.
- 3) Press **OK** to confirm the selection, or LEFT **◀** to keep current settings.

Dimmer on Shutter

Enables automatic closing of the dimmer when the strobe is completely closed.

- 1) Press **OK** – the current settings appear on the display (On or Off).
- 2) Use the UP **▲** and DOWN **▼** keys to enable (On) or disable (Off) the automatic closing of the dimmer.
- 3) Press **OK** to confirm the selection or LEFT **◀** to keep current settings.

AUTO-FOCUS MODE

It lets you select the “Auto-focus Mode” from the two available.

- 1) Press **OK** the current setting appears on the display.
- 2) Use the UP **▲** and DOWN **▼** keys to select one of the following settings:
 - Limited Zoom Range:** The “Autofocus” works only in the optical run that was specifically designed for the projector in question.
 - Complete Zoom Range:** The “Autofocus” also works in overrun
- 3) Press **OK** to confirm the selection or LEFT **◀** to keep the current setting.

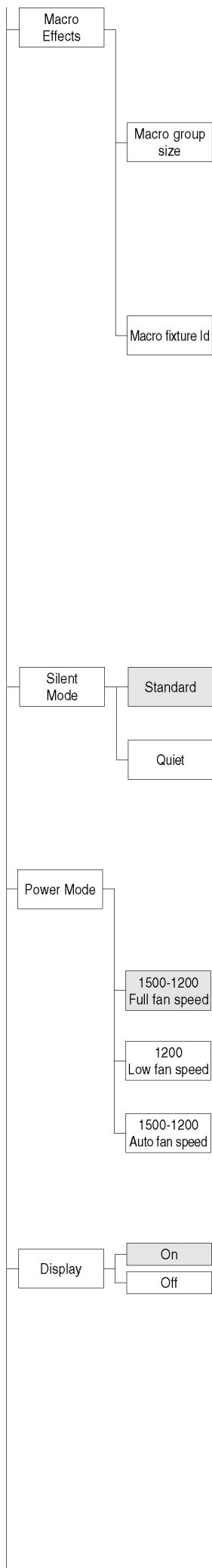

MACRO EFFECTS

It lets you select the “Macro Effects” from the two available.

- 1) Press **OK** the current setting appears on the display.
- 2) Use the UP **▲** and DOWN **▼** keys to select one of the following settings:

Macro group size

It lets you set the number of projectors to be included in the macro mode operation.

- 1) Press **OK**
- 2) Use the UP **▲**, DOWN **▼**, RIGHT keys to set the number of projectors to be included in the “Macro Effect” operation.
- 3) Press **OK** to confirm the selection or LEFT **◀** to keep the current setting.

Macro fixture Id

It lets you attribute an ID address to the projector for the phase displacement for the scene’s starting time in Macro mode.

- 1) Press **OK**
- 2) Use the UP **▲** and DOWN **▼** keys to select one of the following settings:
 - Fixed to X.** (to assign to all the projectors to be included in the Macro operation).
 - Auto by DMX Address:** According to the DMX address, it automatically detects the starting sequence of the scene in the Macro mode (to assign to all the projectors to be included in the Macro operation).
- 3) Press **OK** to confirm the selection or LEFT **◀** to keep the current setting.

SILENT MODE

It lets you select the “Silent Mode” from the two available.

- 1) Press **OK** the current setting appears on the display.
- 2) Use the UP **▲** and DOWN **▼** keys to select one of the following settings:
 - Standard:** Maximum speed and consequently maximum effects noise level.
 - Quiet:** reduces the speed of some effects, thereby reducing their noise level.
- 3) Press **OK** to confirm the selection or LEFT **◀** to keep the current setting.

POWER MODE

Allows you to select a Power Mode from the three available.

- 1) Press **OK** - the current settings appear on the display.
- 2) Use the UP **▲** and DOWN **▼** keys to select one of the following settings:
 - 1500-1200W Full fan speed:** Lamp can change from full-power (1500W) to half-power (1200W) using the LAMP CONTROL channel. Fans always work at Full speed
 - 1200W Low fan speed:** Lamp constantly works in half-power mode (1200W) while the Fan always works at Low speed. With LAMP CONTROL channel you can only switch the lamp ON and OFF.
 - 1500-1200W Auto fan speed:** Lamp can change from full-power (1500W) to half-power (1200W) using the LAMP CONTROL channel. Automatically the fans switch from Full speed to Low speed respectively.
- 3) Press **OK** to confirm the selection or LEFT **◀** to keep current setting.

DISPLAY

Used for automatically reduce brightness on the display after about 30 seconds in idle.

- 1) Press **OK** - the current settings appear on the display (On or Off).
- 2) Use the UP **▲** and DOWN **▼** keys to enable (On) or disable (Off) the decreasing of display brightness.
- 3) Press **OK** to confirm the selection or LEFT **◀** to keep current settings.

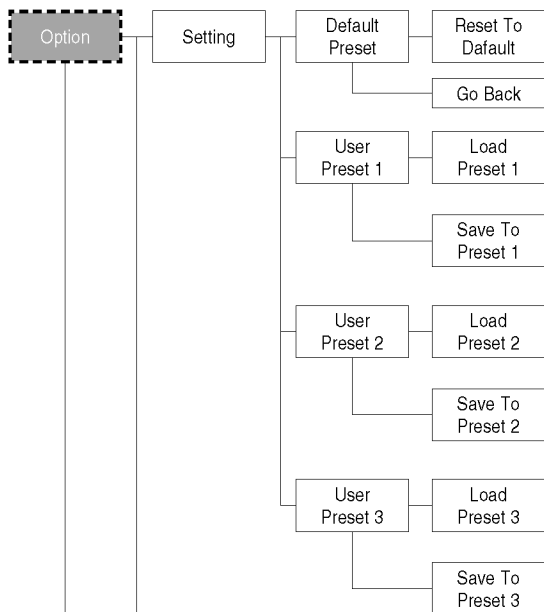

SETTING

Used to save 3 different settings of the items in the options menu and relative submenus.

- 1) Press **OK** - "Default preset" appears on the display.
- 2) Use the UP **▲** and DOWN **▼** keys to select one of the following configurations:
 - **Default preset (*)**
 - **User preset 1**
 - **User preset 2**
 - **User Preset 3**
- 3) Press **OK** - "Load preset X" appears on the display.
- 4) Use the UP **▲** and DOWN **▼** keys to select:
 - Load preset X to recall a previously stored configuration.
 - Save to preset X to store the current configuration.
 a confirmation message (Are you sure?) appears on the display.
- 5) Select YES to confirm the selection or NO to keep the current setting and return to the next higher level.

(*) DEFAULT PRESET

By pressing the RIGHT **▶ key and the LEFT **◀** key simultaneously once entered in the "main menu" it is possible to quickly (short cut) reset the default settings (DEFAULT PRESET).**

Used for restoring default values on all options menu items and relevant submenus.

- 1) Press **OK**, a confirmation message (Are you sure?) appears on the display.
- 2) Select YES to confirm the selection or NO to keep current setting.

OPTION	DEFAULT
Lamp DMX	On
Invert Pan	Off
Invert Tilt	Off
Swap Pan-Tilt	Off
Encoder Pan-Tilt	On
P/T Homing Mode	Standard
Pan Home Def Pos	270 degrees
Tilt Home Def Pos	50%
Colour mixing	CMY
Fixed Wheel Shortcut	On
Macro Color Adjustment	On
Shutter on error	Off
Dimmer on Shutter	Off
Auto-focus mode	Limited zoom range
Silent mode	Standard
Power mode	1500-1200w full fan speed
Display	On

System Errors

Fixture Hours

Total	XXX
Partial	XXX
Reset...	

Lamp Hours

Total	XXX
Partial	XXX
Reset...	

Lamp Strikes

Total	XXX
Partial	XXX
Reset...	

System Version

Board	Revis.	Hw.rv.
CPU brd	x.x.x	x.x
com.dev	x.x	
0: PT-3f	x.x	x.x
1: 8-Ch	x.x	x.x
2: 6-Ch	x.x	x.x
3: 8-Ch	x.x.	x.x
4: 6-Ch	x.x.	x.x

INFORMATION MENU

SYSTEM ERRORS

Shows a list of warnings and messages relevant to errors occurred since the fixtures switching-on.

- Pressing **OK** you are allowed to reset the SYSTEM ERRORS list.
A confirmation message (Are you sure you want to clear error list ?) appears on the display.
- Select YES to reset the list or NO to go back.

FIXTURE HOURS

Used for displaying projector operating hours (total and partial).

- Press **OK** - Hours total and partial appears on the display.
Total counter
Counts the number of projector working life hours (from manufacture to date).
Partial counter
Counts the number of partial projector working life hours since the last reset to date.
- Press **OK** to reset partial projector working hours a confirmation message (Are you sure?) appears on the display.
- Select YES to reset partial projectors counter or NO to keep the current setting and return to the top menu level.

LAMP HOURS

Used for displaying the lamp working hours (total and partial).

- Press **OK** - Hours total and partial appears on the display.
Total counter
Counts the number of projector working hours with the lamp on (from manufacture to date).
Partial counter
Counts the number of lamp working hours since the last reset to date.
- Press **OK** to reset partial lamp working hours, a confirmation message (Are you sure ?) appears on the display.
- Select YES to reset partial counter or NO to keep the current setting and return to the top menu level

LAMP STRIKES

Used for displaying the number of times the lamp was turned on (total and partial).

- Press **OK** - the number of times the lamp was turned on (total and partial) appears on the display.
Total counter
Counts the number of times the lamp was turned on (from manufacture to date).
Partial counter
Counts the number of times the lamp was turned on since the last reset to date.
- Press **OK** to reset partial lamp strikes hours, a confirmation message (Are you sure ?) appears on the display.
- Select YES to reset partial counter or NO to keep the current setting and return to the top menu level

SISTEM VERSION

Used for displaying the software and hardware version of each board installed in the projector.

- CPU brd (CPU board)
 0: PT-3f (Pan / Tilt board)
 1: 8-Ch (8 channel board)
 2: 6-Ch (6 channel board)
 3: 8-Ch (8 channel board)
 4: 6-Ch (6 channel board)

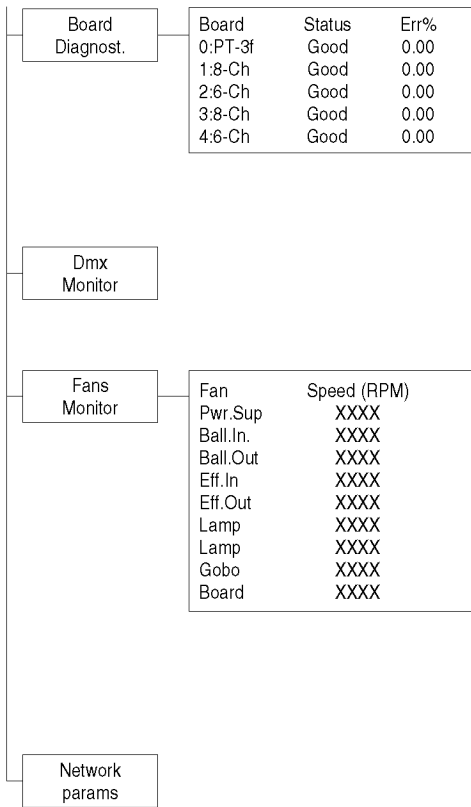

Manual Control

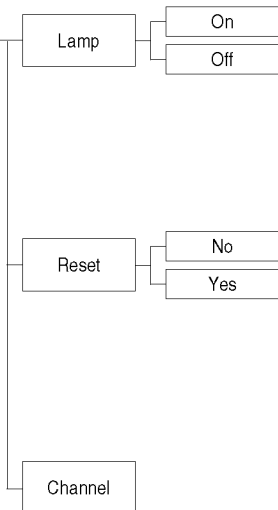

BOARD DIAGNOSTIC

Used for displaying the status error of each board installed in the projector:

- 0: PT-3f (Pan / Tilt board)
- 1: 8-Ch (8 channel board)
- 2: 6-Ch (6 channel board)
- 3: 8-Ch (8 channel board)
- 4: 6-Ch (6 channel board)

DMX MONITOR

Used for displaying the projector DMX channel level in bit (Val) and in percentage (Perc).

FANS MONITOR

Used for displaying the speed of each fan installed in the projector:

- Pwr.Sup (Power supply Fan)
- Ball. IN (Ballast IN Fan)
- Ball. Out (Ballast OUT Fan)
- Eff.IN (Effects IN Fan)
- Eff.OUT (Effects OUT Fan)
- Lamp (Lamp Fan)
- Lamp (Lamp Fan)
- Gobo (Gobo Fan)
- Board (Yoke Board Fan)

NETWORK PARAMS

Allows the "Network" parameters of the projector to be displayed or:

- IP address:** Internet Protocol address (two projectors must not have the same IP address)
- IP mask: 255.0.0.0**
- Mac address:** Media Access Control: the projector's Ethernet Address.

MANUAL CONTROL

LAMP

Used for turning lamp on and off from the projector control panel.

- 1) Press **OK** - the current settings appear on the display (On or Off).
- 2) Use the UP **▲** and DOWN **▼** keys to turn the lamp on (On) or off (Off)
- 3) Press **OK** to confirm the selection or LEFT **◀** to keep current settings and return to the top level.

RESET

Used for resetting the projector.

- 1) Press **OK** to reset the projectors, a confirmation message (Are you sure ?) appears on the display.
- 2) Select YES to starting reset the fixture or NO to keep the current setting and return to the top menu level.

CHANNEL

Used for setting channel levels from the projector control panel.

- 1) Press **OK** - the first channel appears on the display.
- 2) Use the UP **▲** and DOWN **▼** keys to select the required channel:
- 3) Press **OK** and use the UP **▲** and DOWN **▼** keys to select the required DMX level (value between 0 and 255).
- 4) Press LEFT **◀** to return to the top menu level.

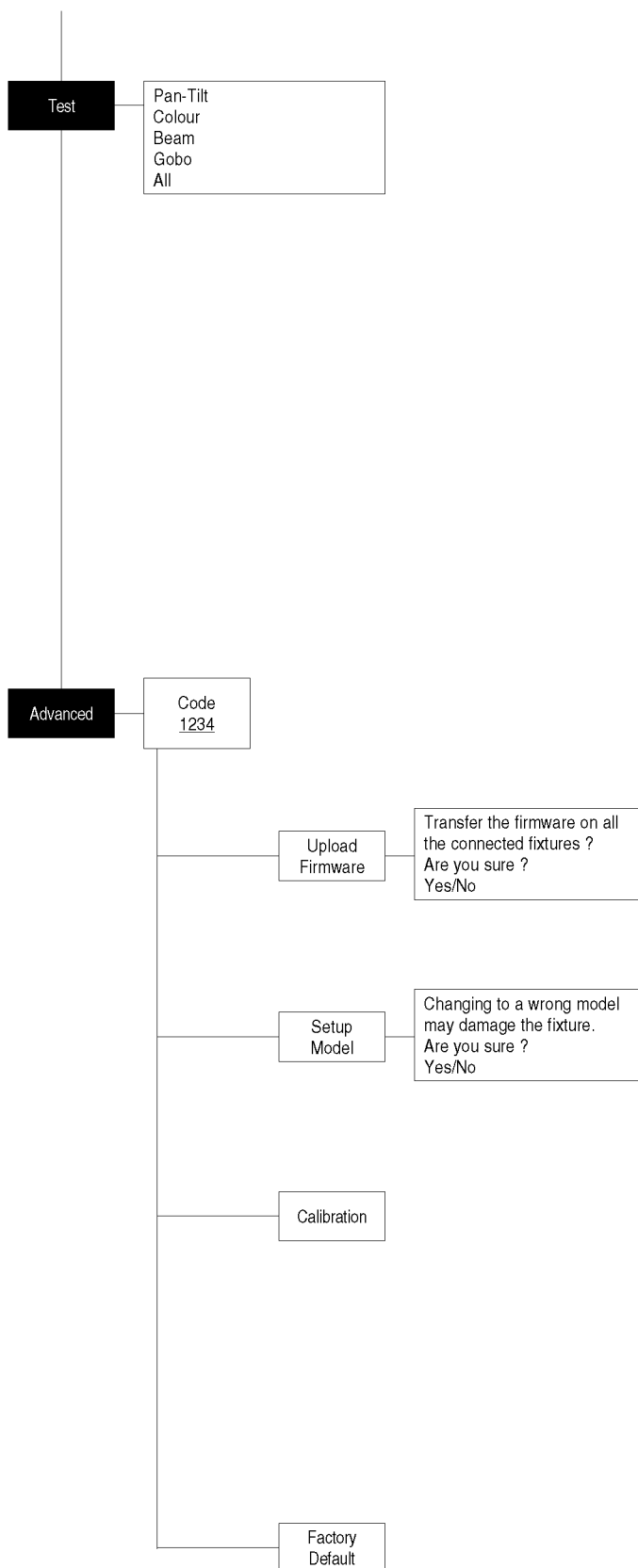

TEST MENU

AUTOTEST

Allows you to check the proper functioning of effects.

- 1) Press **OK**.
- 2) Use the UP **▲** and DOWN **▼** keys to select the required test.
- 3) Press **OK** to confirm the selection or LEFT **◀** to return to the top menu level.

Test sequence:

Pan - Tilt effects (Pan & Tilt)

Colour effects (CMY, colour wheel, CTO)

Beam effects (Stopper-Strobe / Dimmer / Iris / Prism / Frost, Focus, Zoom, Animation disk)

Gobo effects (Fixed gobo / Rotating gobo)

All effects

ADVANCED MENU

To enable the "Advanced Menu" set up the "Access code" (1234) using the UP **▲**, DOWN **▼**, RIGHT **▶** keys.

Press **OK** - "Menu advanced" appears on the display

UPLOAD FIRMWARE

Allows you to transfer the firmware from 1 fixture to all the connected fixtures.

- 1) Press **OK**, a confirmation message appears on the display.
- 2) Select YES to start the firmware loading or NO to keep the current setting and return to the top menu level

SETUP MODEL

Allows you to change the default model of projector.

- 1) Press **OK** a confirmation message appears on the display.
- 2) Select YES to define the model of projector or NO to keep the current setting and return to the top menu level.

CALIBRATION

Allows you to adjust effects from the control panel to obtain perfect uniformity between the projectors.

- 1) Press **OK** - "channels" appears on the display.
- 2) Using the UP **▲** and DOWN **▼** keys, select the effect you wish to regulate.
- 3) Press **OK** and use the RIGHT **▶**, UP **▲** and DOWN **▼** buttons to make the adjustment by setting a value between 0 and 255.
- 4) Press **OK** to confirm the selection or LEFT **◀** to keep current settings and return to the top level.

FACTORY DEFAULT

Allows you to restore default values of all channels (128).

- 1) Press **OK** – a confirmation message appears on the display (Reset calibration to factory default ?).
- 2) Select YES to reset calibration to factory default or NO to keep the current setting and return to the top menu level.

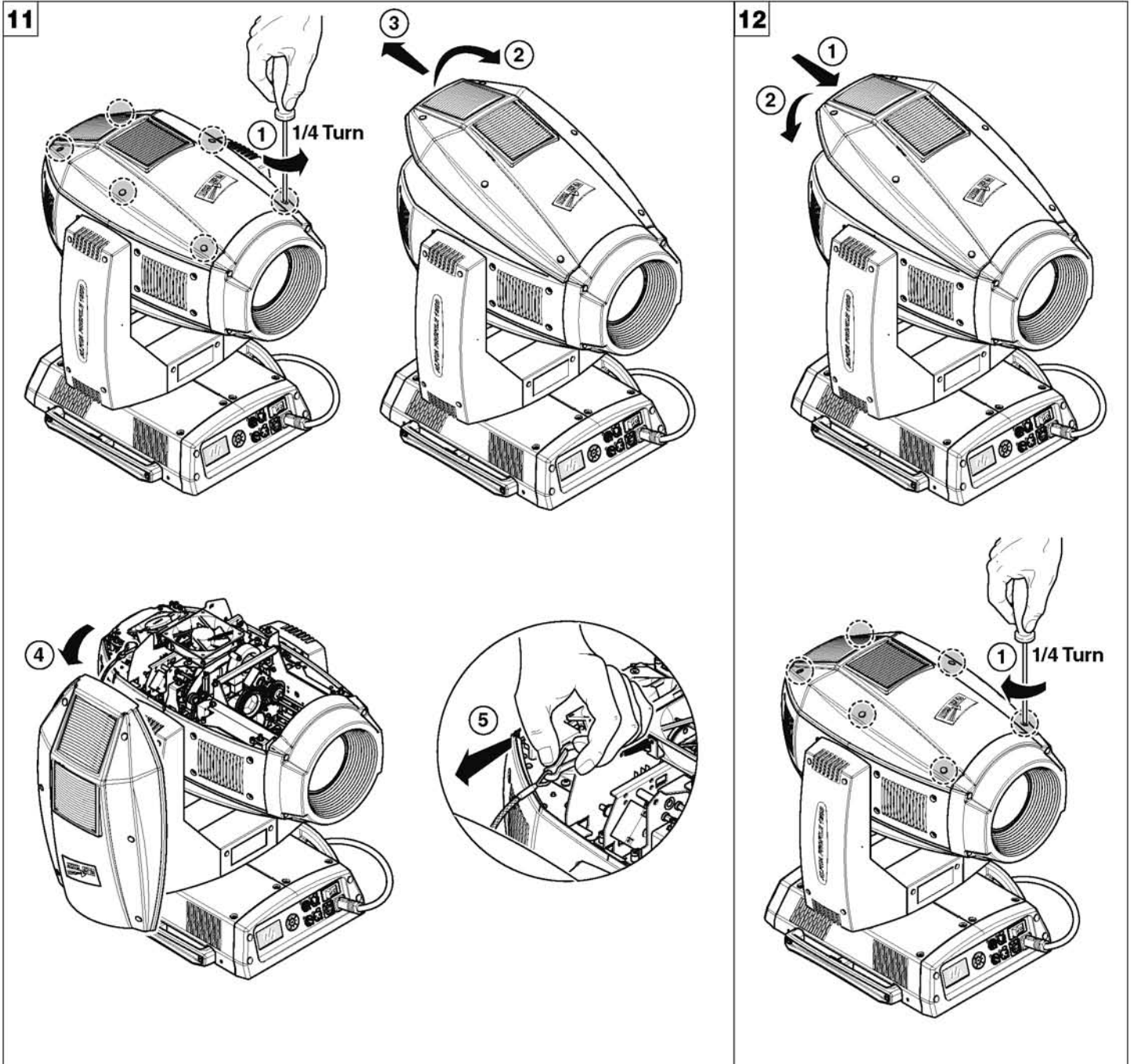

Locking and releasing Pan and Tilt movements - Refer to the instructions in the UNPACKING AND PREPARATION section.

Opening the head covers - Fig. 11.

Closing the head covers - Fig. 12.

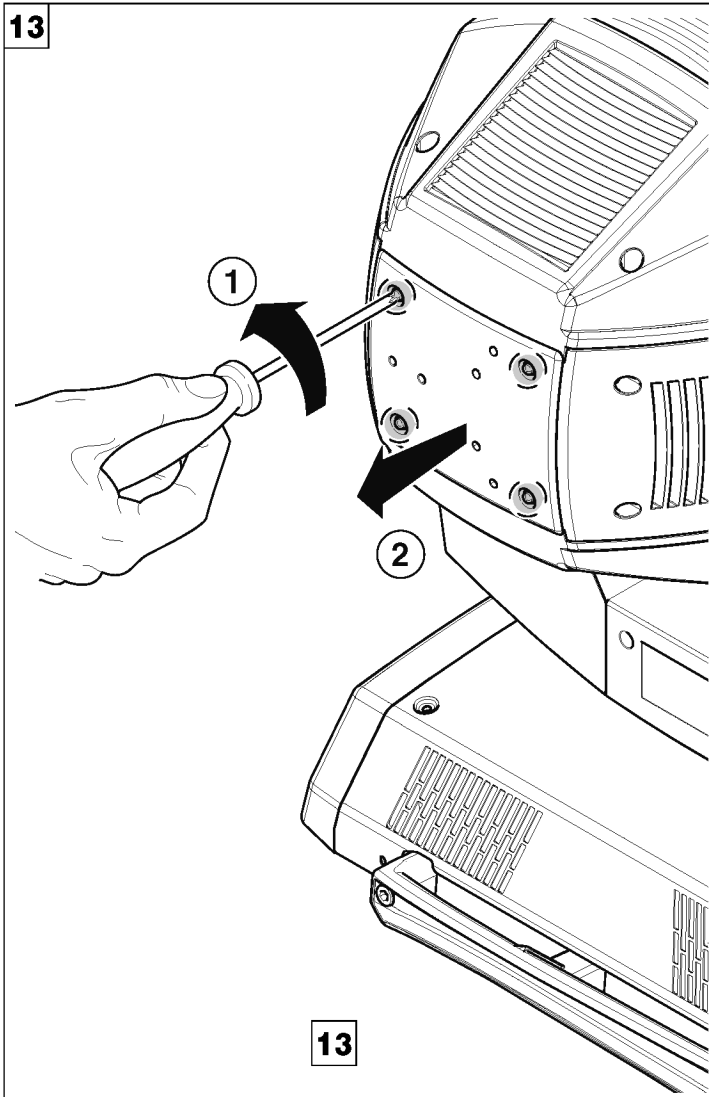

Opening and closing lamp compartment - Fig. 13

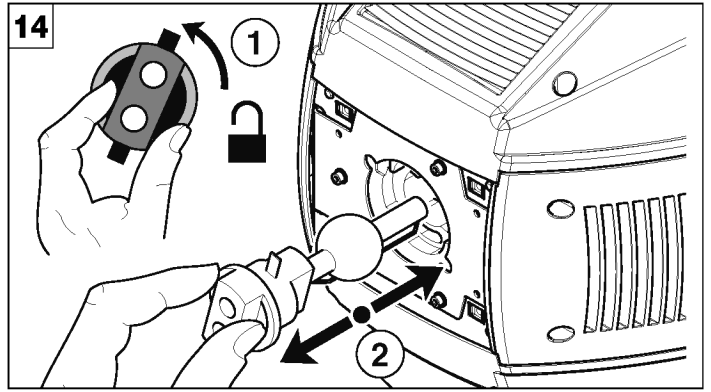

Lamp change - Fig 14

Take the new lamp out of its package and insert in the fitting.

WARNING: do not touch the lamp's envelope with bare hands. Should this happen, clean the bulb with a cloth soaked in alcohol and dry it with a clean, dry cloth.

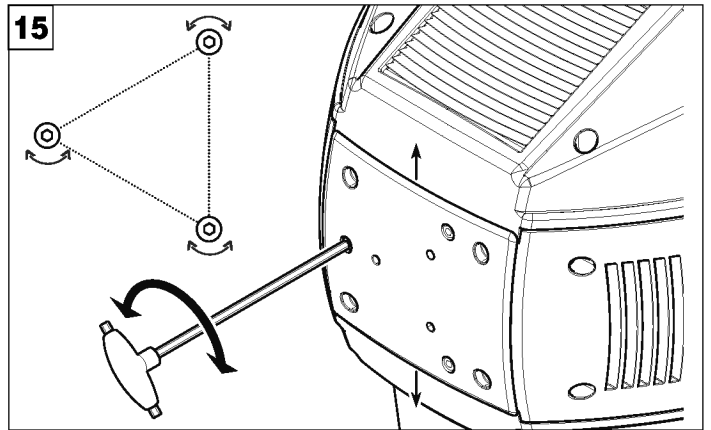

Lamp regulation - Fig. 15

To centre the lamp, turn the three adjusting screws as shown in the figure.

CAUTION:

Fast lamp ON-OFF cycles (for example 10 minutes ON / 10 minutes OFF) will reduce the lamp life.

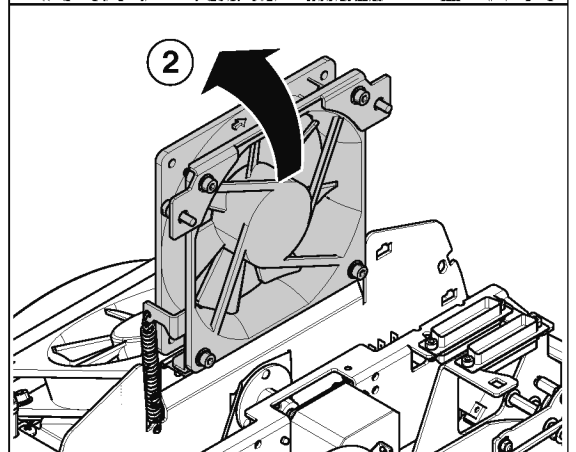
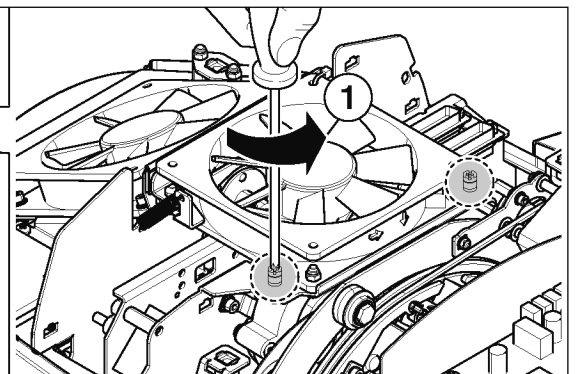
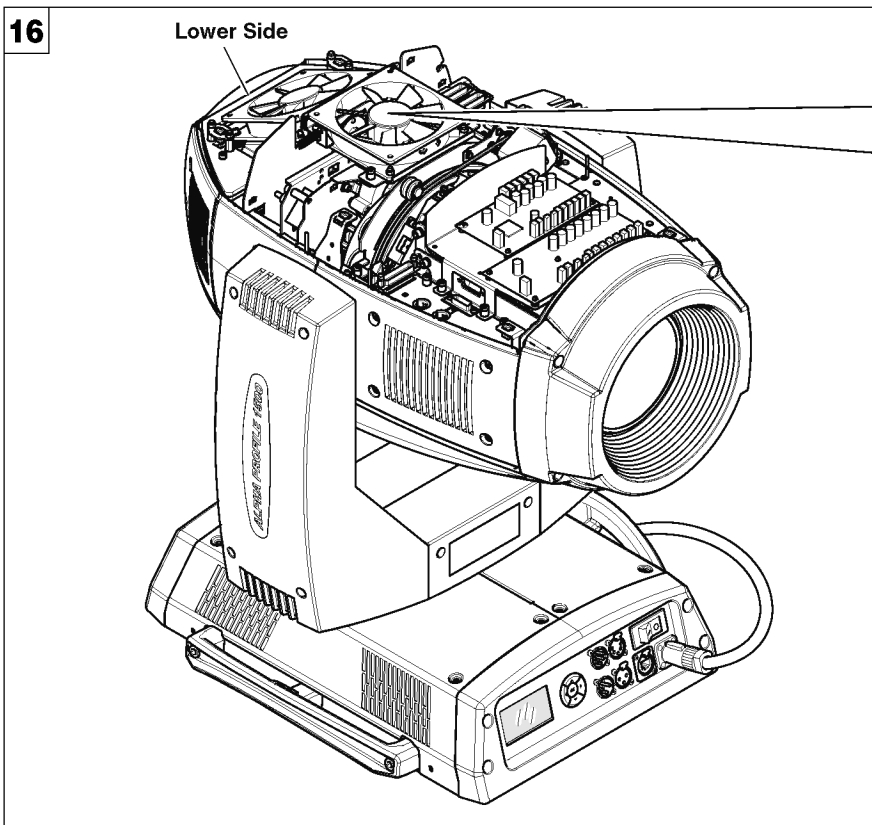

Fan support plate opening and closing (Lower side) - Fig. 16

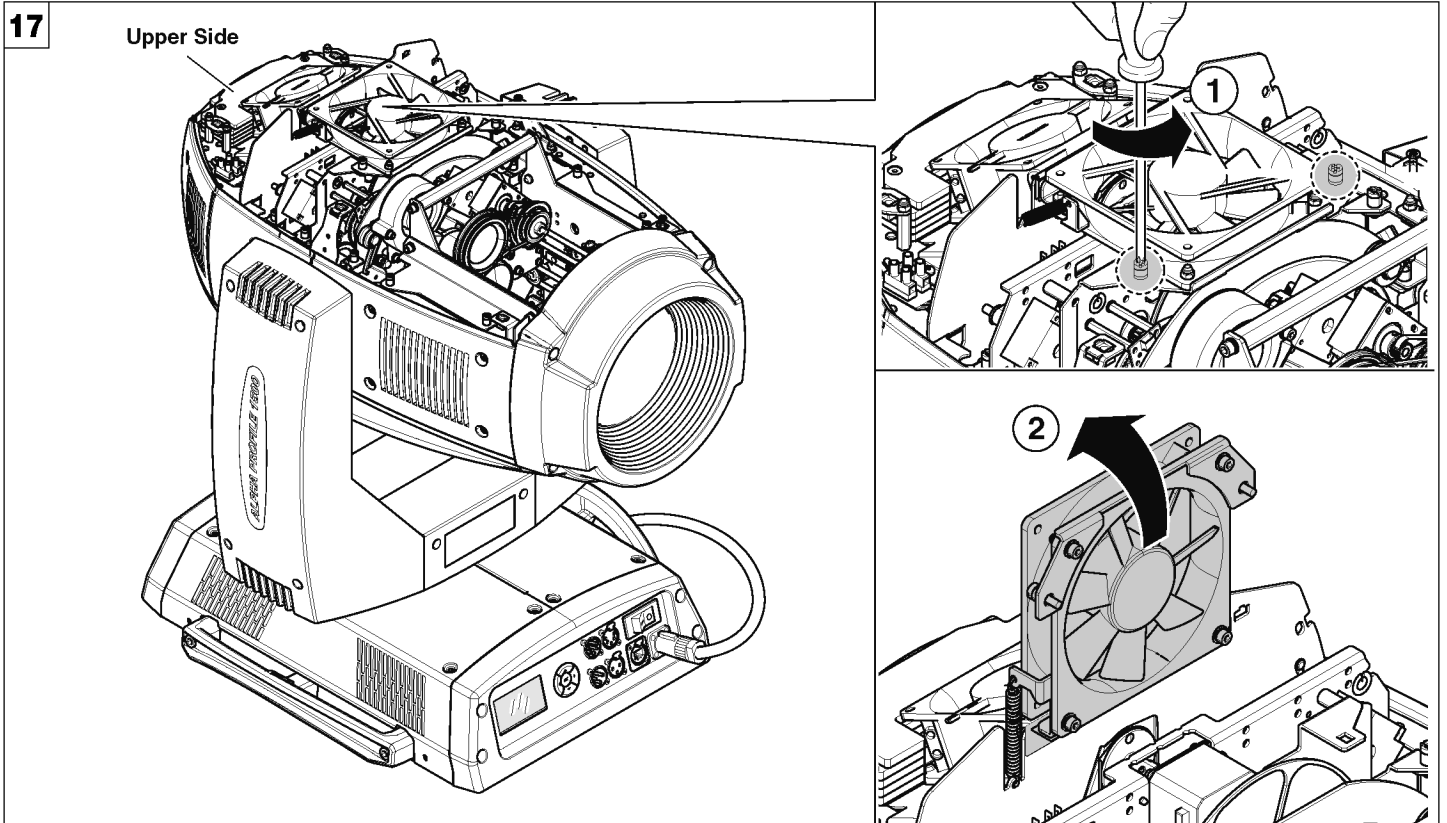

Fan support plate opening and closing (Upper side) - Fig. 17

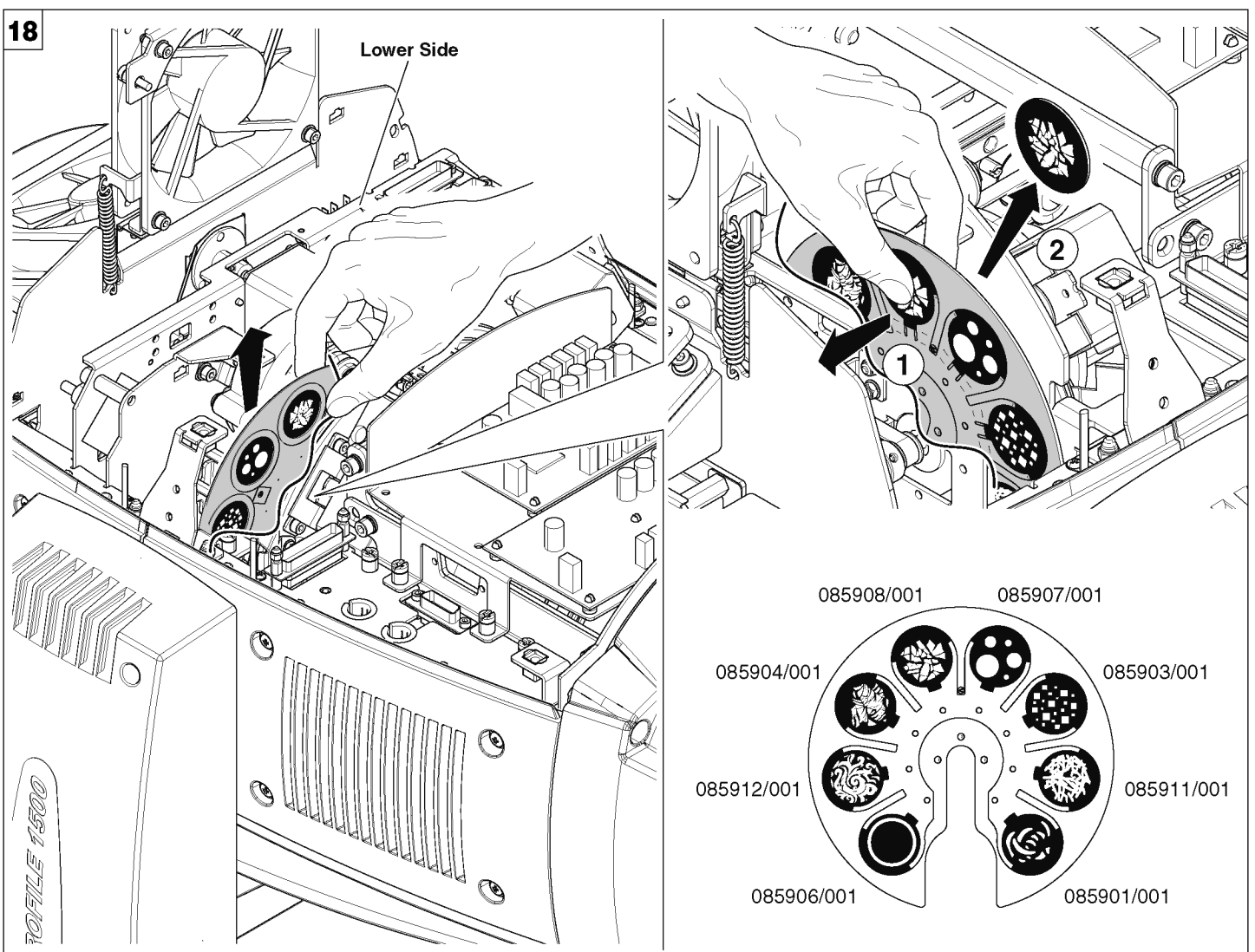

Replacing fixed gobos (\varnothing 31.5 mm - max 25 mm image - thickness max 1 mm) - Fig. 18
IMPORTANT: Please contact CLAY PAKY before using customized gobos.

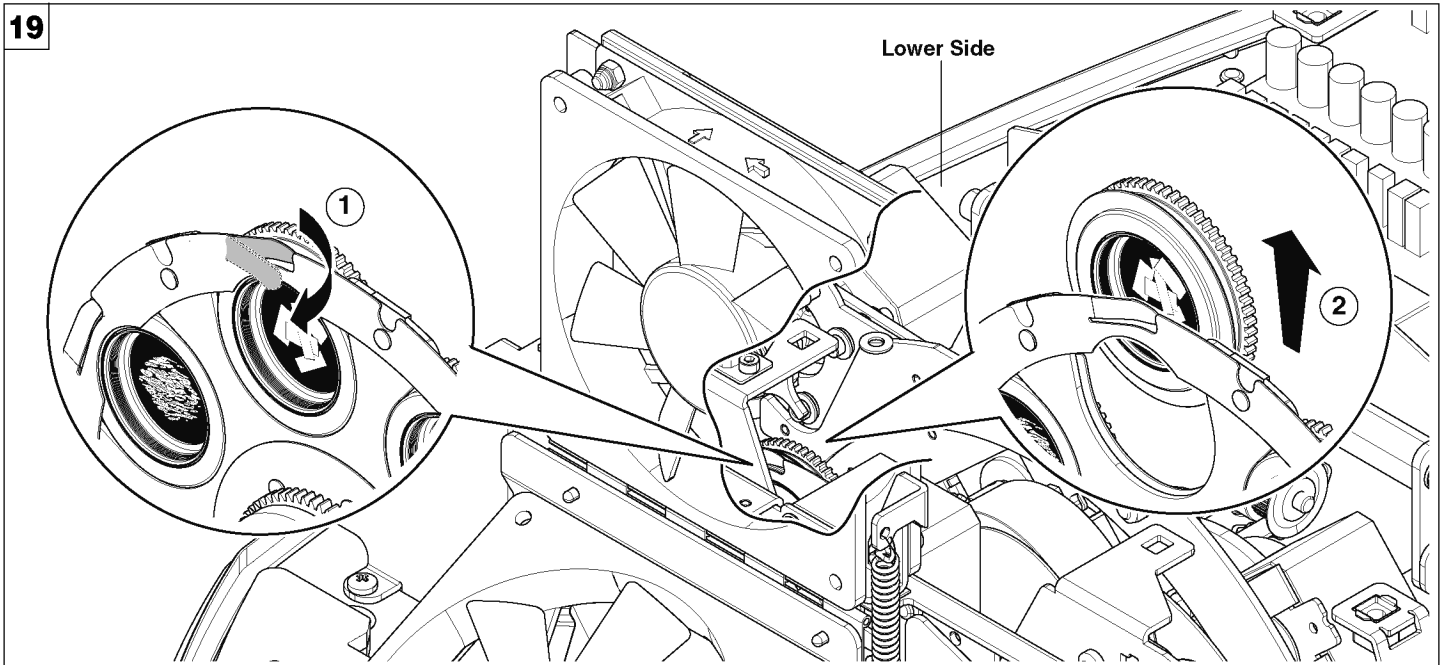

Bearing group replacement - Fig. 19

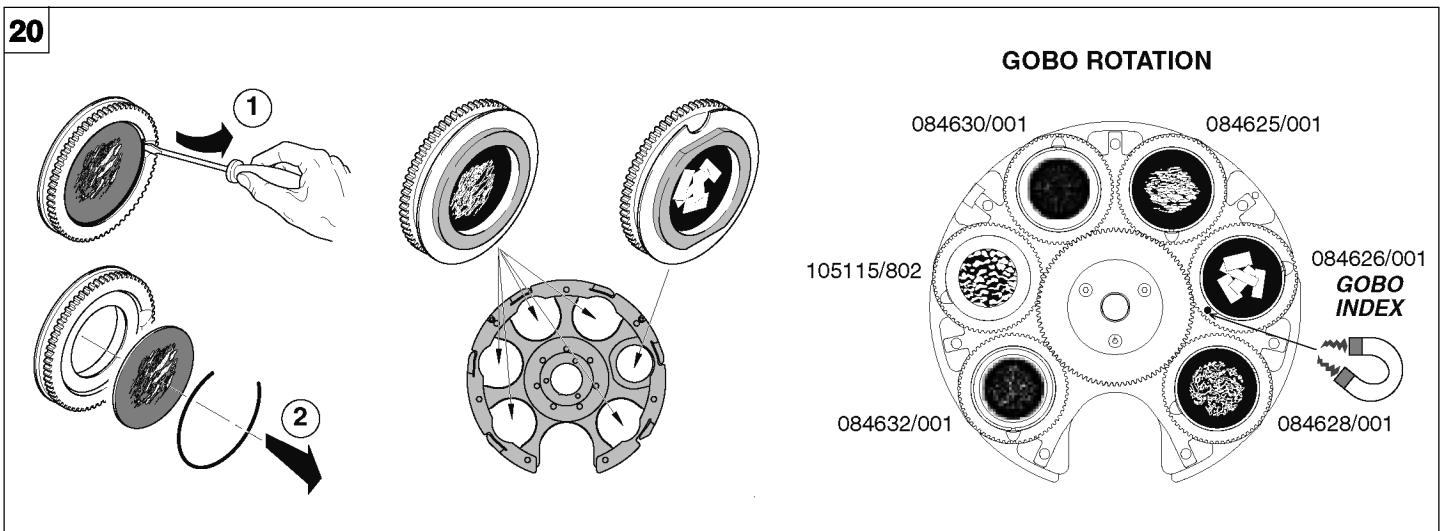

Replacing rotating gobos (\varnothing 37.5 mm - max 25 mm image - thickness 1 mm) - Fig. 20

IMPORTANT: Please contact CLAY PAKY before using customized gobos.

IMPORTANT: Use only glass gobos on the rotating gobos wheels.

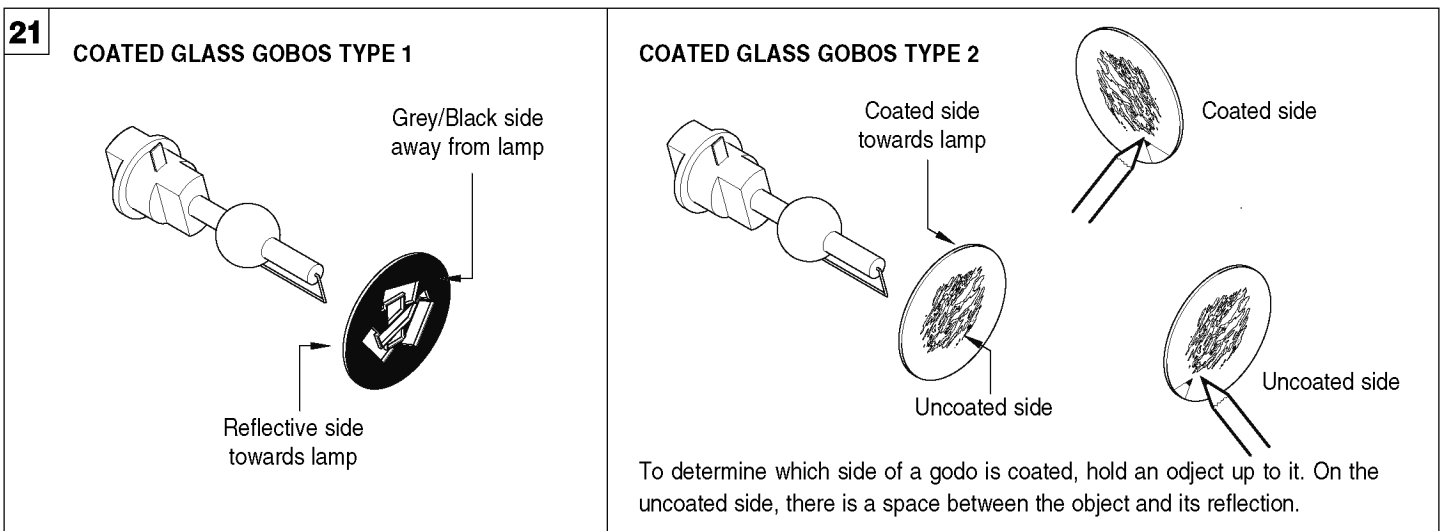

Gobo orientation - Fig. 21

The pictures shown the correct gobos orientation.

22

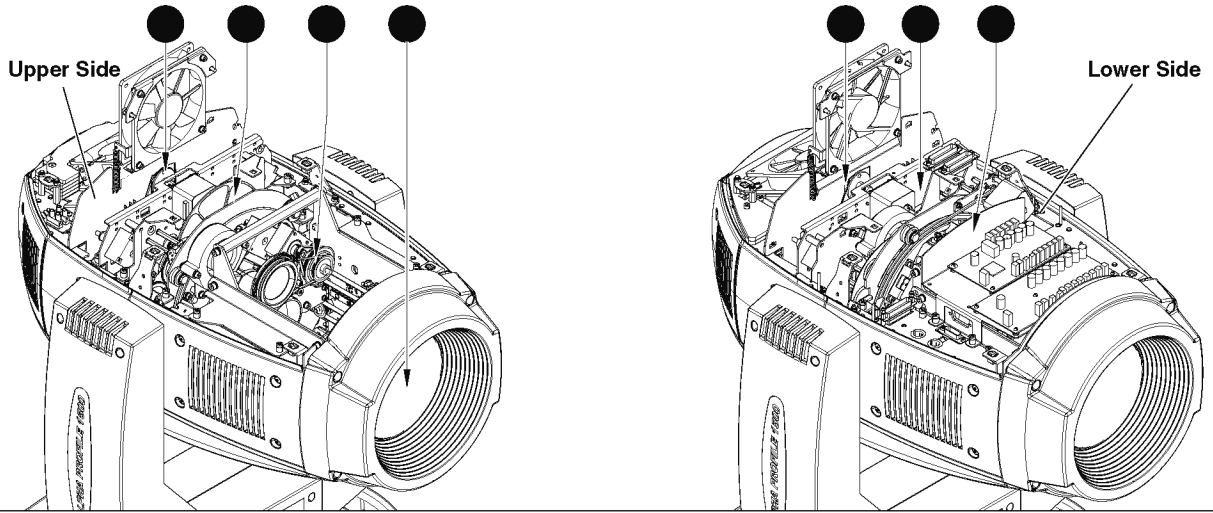

Periodical cleaning - Fig. 22

To ensure optimal operation and performance for a long time it is essential to periodically clean the parts subject to dust and grease deposits. The frequency with which the following operations are to be carried out depends on various factors, such as the amount of the effects and the quality of the working environment (air humidity, presence of dust, salinity, etc.).

Use a soft cloth dampened with any detergent liquid for cleaning glass to remove the dirt from the reflectors, from the lenses and filters. It is recommended that the projector undergoes an annual service by a qualified technician for special maintenance involving at least the following operations:

- General cleaning of internal parts.
- Restoring lubrication of all parts subject to friction, using lubricants specifically supplied by Clay Paky.
- General visual check of the internal components, cabling, mechanical parts, etc.
- Electrical, photometric and functional checks; eventual repairs.

23

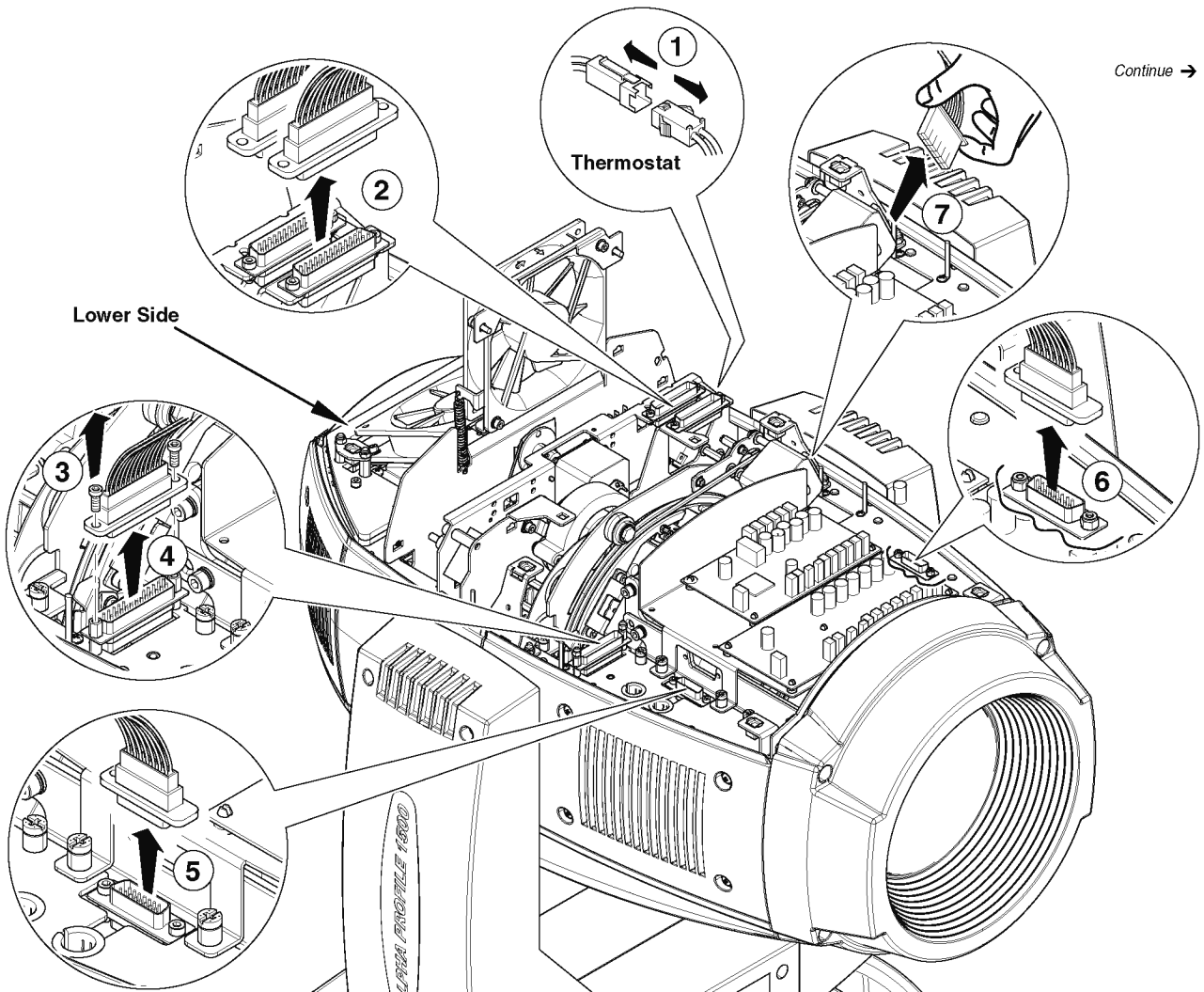

Extraction of the effect modules: Preliminary operations - Fig. 23

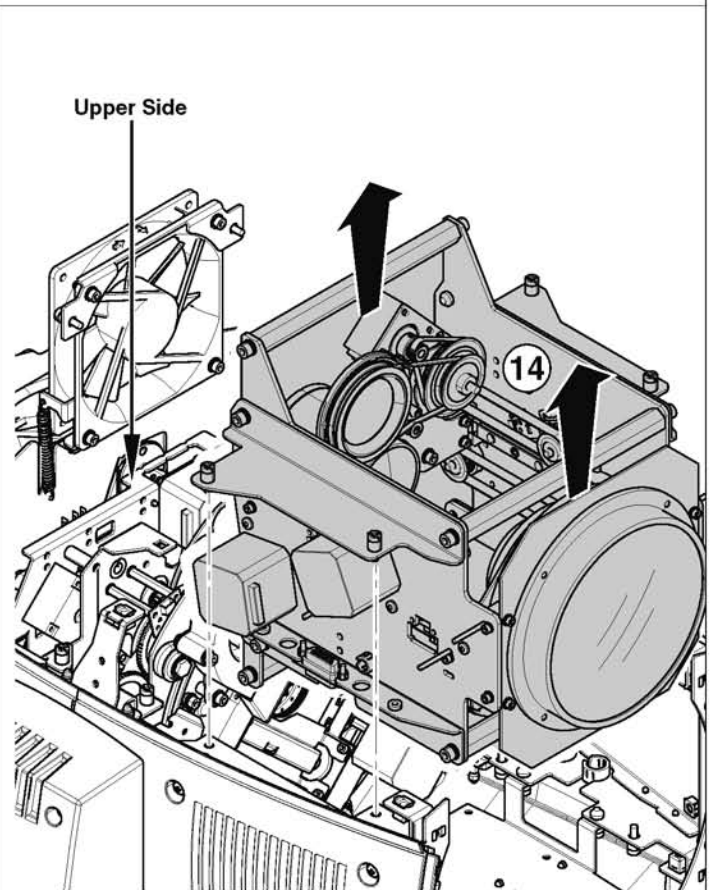
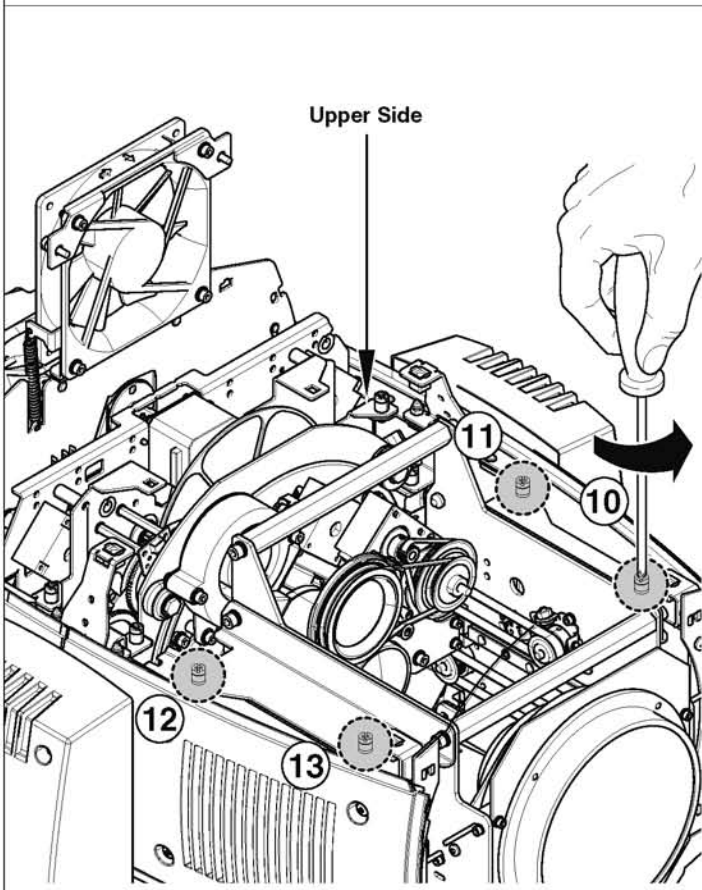
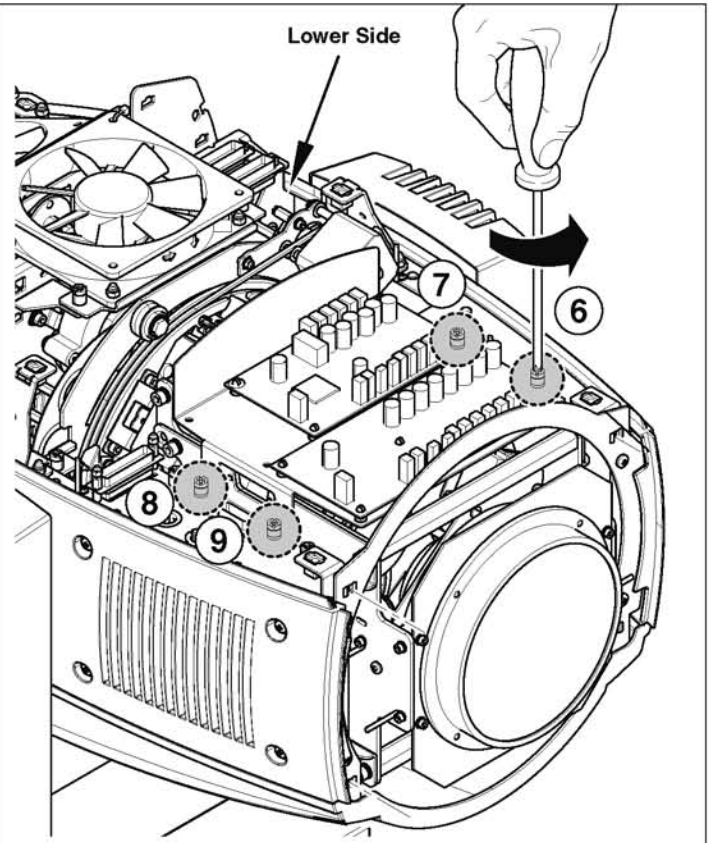
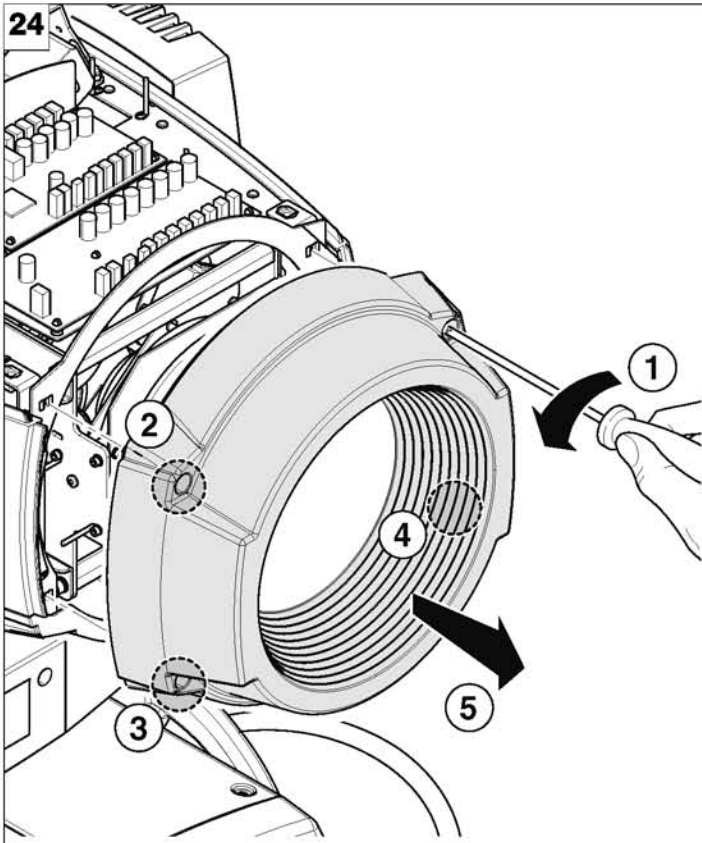

Extraction of the effect modules - Fig. 24

IMPORTANT: Grasp the modules using the support structure and not the details which could get damaged.

Insertion of the effect modules: Repeat the operations indicated in Fig. 24 and 25 in reverse order

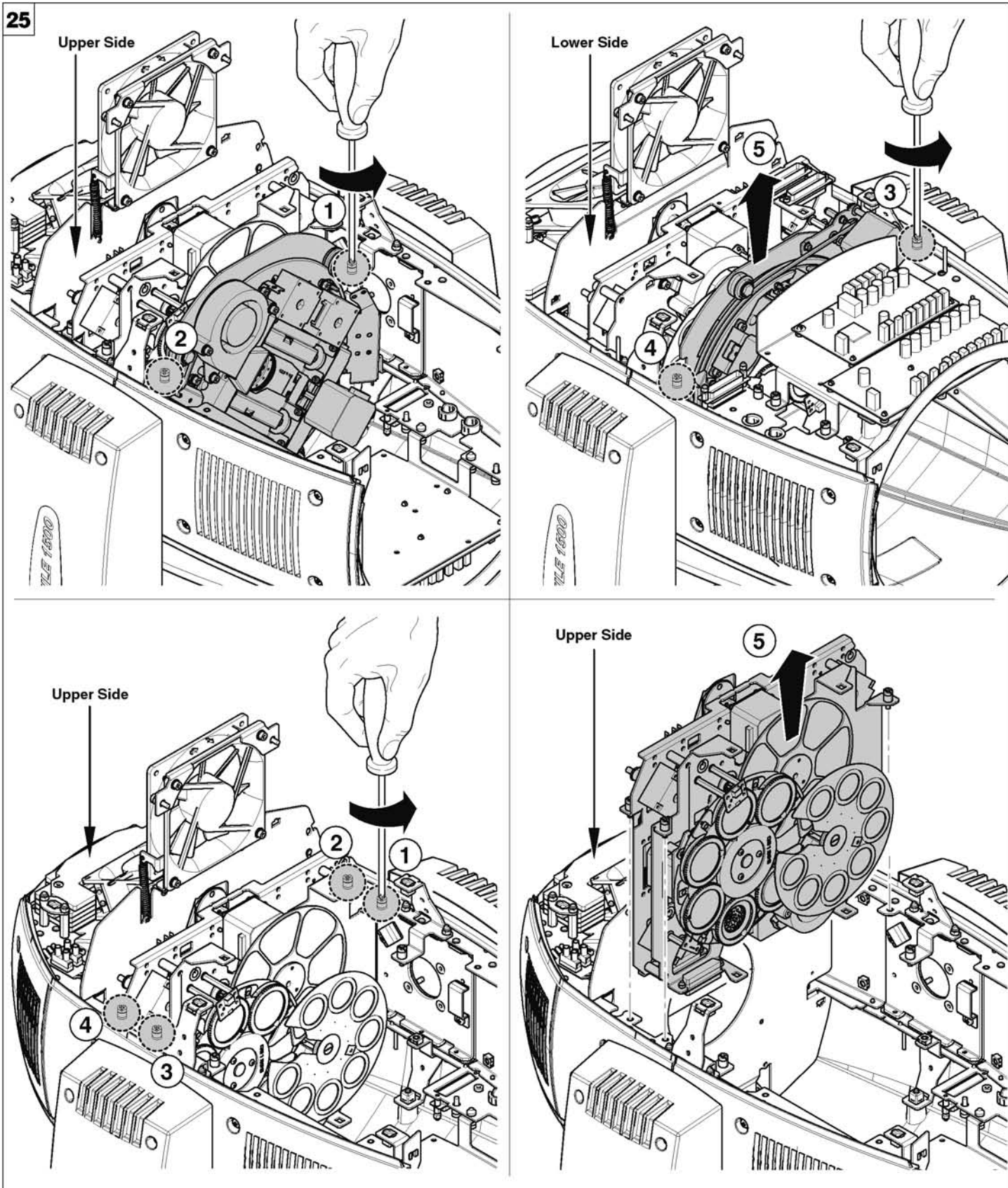

Extraction of the effect modules - Fig 25

IMPORTANT: Grasp the modules using the support structure and not the details which could get damaged.

Insertion of the effect modules: Repeat the operations indicated in Fig. 24 and 25 in reverse order

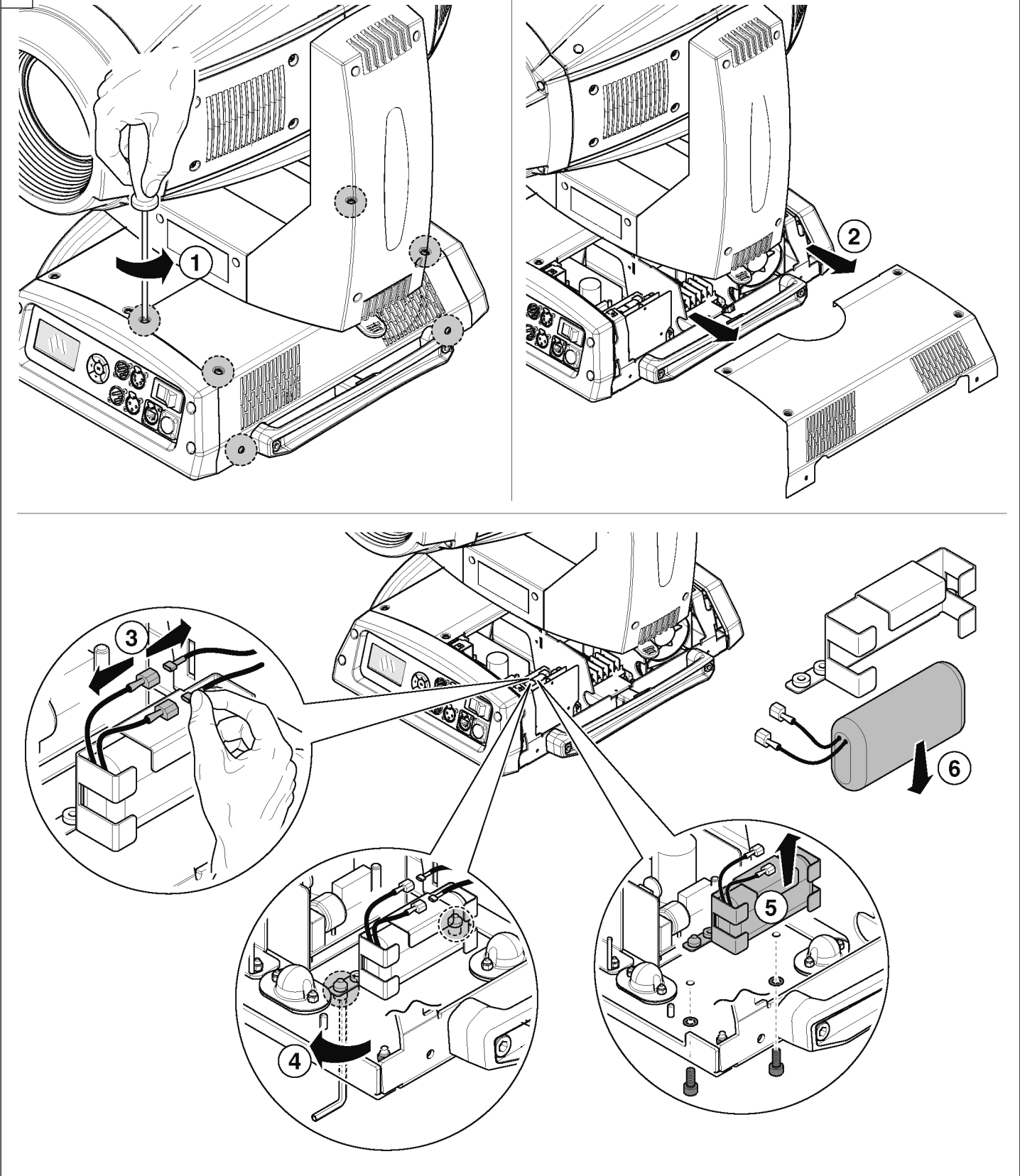

Battery removal - Fig. 26



This product contains a rechargeable lead-acid or lithium iron tetraphosphate battery. To preserve the environment, please dispose the battery at the end of its life according to the regulation in force.

TECHNICAL INFORMATION

Power supplies available

200-240V 50/60Hz

Input power

2000VA a 230V 50Hz.

Total output

Max 27000 lumens.

Lamp

Discharge lamp.

Type HTI 1500W/60/P50-L Lok-it Osram (L10102)

- Cap PGJ50
- Colour temperature 6000 K
- Luminous flux 135000 lm
- Average life 750 h
- Any working position

Motors

31 stepper motors, operating with microsteps, totally microprocessor controlled.

Optical unit

Elliptic reflector with high luminous efficiency

Channels

Max 41 control channels.

Inputs

- DMX 512
- Ethernet

Movable body

- Movement by means of two stepper motors, controlled by microprocessor.
- Automatic repositioning of PAN and TILT after accidental movement not controlled by control unit.
- Travel:
 - PAN = 540°
 - TILT = 252°
- Maximum speeds:
 - PAN = 4.0 sec (360°)
 - TILT = 3.2 sec (252°)
- Resolution:
 - PAN = 2.11°
 - PAN FINE = 0.008°
 - TILT = 0.98°
 - TILT FINE = 0.004°

IP20 protection rating

- Protected against the entry of solid bodies larger than 12mm (0.47").
- No protection against the entry of liquids.

CE Marking

Complies with the following European Directives

- 2006/95/EC (LVD)
- 2004/108/EC (EMC)
- 2011/65/EU (RoHS).

Safety Devices

- Bipolar circuit breaker with thermal protection.
- Automatic break in power supply in case of overheating or failed operation of cooling system.

Cooling

Forced ventilation with axial fans.

Body

- Aluminium structure with die-cast plastic cover.
- Two side handles for transportation.
- Device locking PAN and TILT mechanisms for transportation and maintenance.

Working position

Functioning in any position.

Weights

50.35 Kg (110lbs, 12ozs).

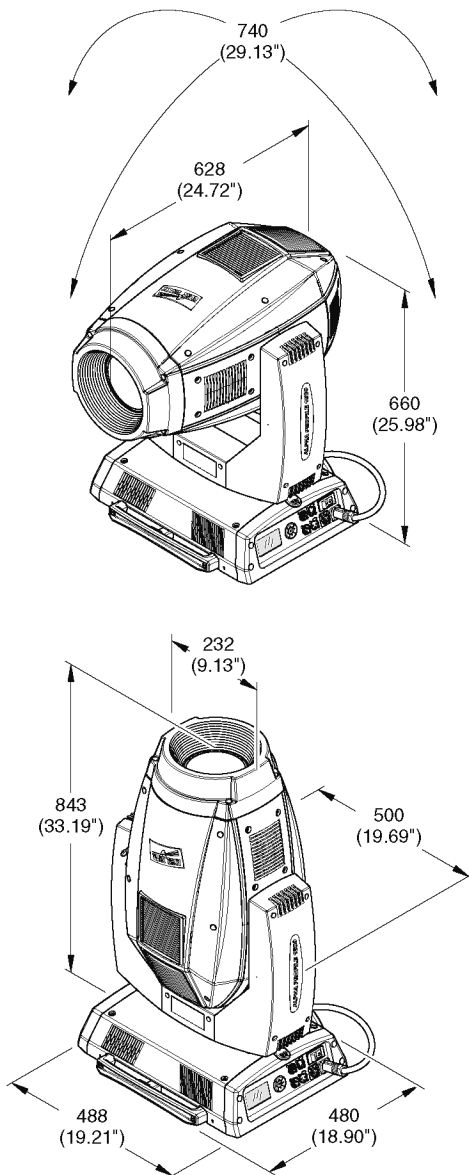

CAUSE AND SOLUTION OF PROBLEMS

THE PROJECTOR WILL NOT SWITCH ON			PROBLEMS
ELECTRONICS NON-OPERATIONAL			
DEFECTIVE PROJECTION			
REDUCED LUMINOSITY			
POSSIBLE CAUSES			CHECKS AND REMEDIES
●		No mains supply.	Check the power supply voltage.
●	●	Lamp exhausted or defective.	Replace the lamp. (See instructions).
	●	Signal transmission cable faulty or disconnected.	Replace the cables.
	●	Incorrect addressing.	Check addresses (see instructions).
	●	Fault in the electronic circuits.	Call an authorised technician.
	●	Lenses or reflector broken	Call an authorised technician.
	●	Dust or grease deposited.	Clean (see instructions).

CHANNEL FUNCTION

ALPHA PROFILE 1500

NB: To prevent accidental breakage of the effects, which could collide with each other during transport, before switching the projector OFF check that all the projector Channels have been excluded (DMX level = 0%).

CHANNEL	CHANNEL MODE	
	STANDARD	VECTOR
1	CYAN	CYAN
2	MAGENTA	MAGENTA
3	YELLOW	YELLOW
4	C.T.O	C.T.O
5	COLOUR WHEEL	COLOUR WHEEL
6	MACRO COLOURS	MACRO COLOURS
7	STOP/STROBE	STOP/STROBE
8	DIMMER	DIMMER
9	DIMMER FINE	DIMMER FINE
10	IRIS	IRIS
11	STATIC GOBO CHANGE	STATIC GOBO CHANGE
12	ROTATING GOBO CHANGE	ROTATING GOBO CHANGE
13	GOBO ROTATION	GOBO ROTATION
14	GOBO FINE	GOBO FINE
15	ROTATING PRISM CHANGE	ROTATING PRISM CHANGE
16	PRISM ROTATION	PRISM ROTATION
17	FROST INSERTION	FROST INSERTION
18	BLADE UP1	BLADE UP1
19	BLADE UP2	BLADE UP2
20	BLADE DW1	BLADE DW1
21	BLADE DW2	BLADE DW2
22	BLADE RG1	BLADE RG1
23	BLADE RG2	BLADE RG2
24	BLADE LF1	BLADE LF1
25	BLADE LF2	BLADE LF2
26	FRAMING ROTATION	FRAMING ROTATION
27	FOCUS	FOCUS
28	FOCUS FINE	FOCUS FINE
29	ZOOM	ZOOM
30	AUTOFOCUS DISTANCE	AUTOFOCUS DISTANCE
31	AUTOFOCUS ADJUSTMENT	AUTOFOCUS ADJUSTMENT
32	MACRO EFFECTS	MACRO EFFECTS
33	PAN	PAN
34	PAN FINE	PAN FINE
35	TILT	TILT
36	TILT FINE	TILT FINE
37	FUNCTION	FUNCTION
38	RESET	RESET
39	LAMP CONTROL (with Option "Lamp DMX" ON)	LAMP CONTROL (with Option "Lamp DMX" ON)
40		PAN-TILT TIME
41		COLOUR TIME
42		BEAM TIME
43		GOBO TIME

NOTE: On conclusion of resetting in case of absence of DMX signal, Pan & Tilt move to the "Home" position (Pan 128 bit - Tilt 128 bit) all the others channels stay at 0 bit.

• COLOUR MIXING - channel 1 - 2 - 3

Operation with option color mixing: RGB

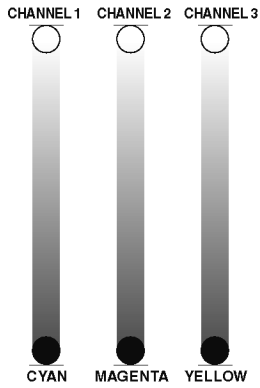

BIT	EFFECT
255	COLOUR EXCLUDED
0	COLOUR INSERTED

IMPORTANT: The lamp dim to half power 1 second after all the 3 channels stay at 0 bit level. The lamp goes back to full power when the channels level is put higher than 0 bit.

Operation with option color mixing: CMY

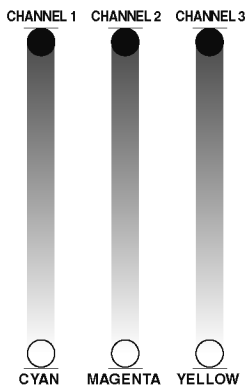

BIT	EFFECT
255	COLOUR INSERTED
0	COLOUR EXCLUDED

IMPORTANT: The lamp dim to half power 1 second after all the 3 channels stay at 255 bit level. The lamp goes back to full power when the channels level is put lower than 255 bit.

• C.T.O. - channel 4



BIT	EFFECT
255	FILTER INSERTED
0	FILTER EXCLUDED

• COLOUR WHEEL - channel 5



BIT	EFFECT
255	FAST ROTATION 160 rpm
128	SLOW ROTATION 0.2rpm
117	BLUE
97	ORANGE
77	AQUAMARINE
58	GREEN
39	PINK
20	RED
0	WHITE

• MACRO COLOURS - channel 6

COLOR NAME	BIT	ROSCO CODE	LEE CODE	CYAN BIT	MAGENTA BIT	YELLOW BIT	CTO BIT	WHEEL BIT
Unused Range	148-255	-	-	-	-	-	-	-
Half CT straw	146-147	442	442	0	0	34	190	0
Lighter blue	144-145	353	353	226	0	149	138	0
Glacier blue	142-143	352	352	220	0	129	138	0
Fuschia pink	140-141	345	345	109	186	77	120	0
Mallard green	138-139	325	325	255	0	0	236	58
Jade	136-137	323	323	127	0	162	0	77
3/4 CT Orange	134-135	285	285	0	36	61	217	0
3/4 CTB	132-133	281	281	85	79	87	54	0
Half minus green	130-131	248	248	60	19	86	75	39
Minus green	128-129	247	247	60	71	86	75	39
1/4 CTO	126-127	206	206	62	71	123	122	0
1/2 CTO	124-125	205	205	25	26	45	131	0
Full CT Orange	122-123	204	204	0	44	58	234	0
1/4 CTB	120-121	203	203	75	54	91	109	0
1/2 CTB	118-119	202	202	85	71	84	89	0
Full CTB	116-117	201	201	94	79	80	0	0
Alice Blue	114-115	197	197	236	51	0	205	0
Congo Blue	112-113	181	181	251	241	0	255	0
Dark Lavender	110-111	180	180	195	170	0	160	0
Chrome Orange	108-109	179	179	0	98	255	255	0
Lagoon blue	106-107	172	172	224	0	121	40	79
Deep Lavender	104-105	170	170	100	129	77	120	0
Lilac tint	102-103	169	169	41	59	39	120	0
Daylight Blue	100-101	165	165	210	73	105	88	0
Flame red	98-99	164	164	0	255	227	255	97
Bastard amber	96-97	162	162	0	26	0	199	0
Deep Orange	94-95	158	158	0	148	255	255	0
Pink	92-93	157	157	0	159	0	255	0
Pale rose	90-91	154	154	0	48	0	189	0
Pale Gold	88-89	152	152	0	60	98	138	0
Bright rose	86-87	148	148	0	255	0	255	0
Apricot	84-85	147	147	0	81	55	255	0
Bright Blue	82-83	141	141	182	0	99	92	77
Primary green	80-81	139	139	0	0	0	231	58
Light green	78-79	121	121	0	0	255	0	77
Pale green	76-77	138	138	105	0	179	100	0
Special Lavender	74-75	137	137	97	105	72	90	0
Pale Lavender	72-73	136	136	73	102	44	120	0
Deep golden amber	70-71	135	135	0	255	255	255	0
Golden amber	68-69	134	134	0	142	234	110	0
Medium blue	66-67	132	132	255	152	127	0	77
Marine blue	64-65	131	131	60	0	106	73	77
Bright pink	62-63	128	128	0	255	0	197	0
Mauve	60-61	126	126	0	255	0	255	74
Fern Green	58-59	122	122	173	0	235	89	0
Leaf green	56-57	121	121	136	0	241	64	0
Deep Blue	54-55	120	120	255	229	58	128	77
Dark blue	52-53	119	119	255	161	0	0	77
Light blue	50-51	118	118	245	0	145	138	0
Steel blue	48-49	117	117	167	0	141	165	0
Medium blue green	46-47	116	116	189	0	157	91	77
Peacock blue	44-45	115	115	136	0	128	91	77
Dark pink	42-43	111	111	0	139	0	220	0
Light Salmon	40-41	109	109	50	121	58	230	0
English rose	38-39	108	108	0	62	0	247	0
Light rose	36-37	107	107	0	95	0	220	0
Primary red	34-35	106	182	0	0	0	0	20
Orange	32-33	105	105	0	182	255	76	0
Deep amber	30-31	104	104	0	26	199	223	0
Straw	28-29	103	103	58	17	104	176	0
Light amber	26-27	102	102	0	0	171	193	0
Yellow	24-25	101	101	0	0	255	149	0
Spring yellow	22-23	100	100	80	0	227	157	0
Dark Yellow Green	20-21	90	90	255	0	255	204	0
Lime green	18-19	88	88	118	0	241	124	0
Just Blue	16-17	79	79	255	77	0	204	0
Tokyo Blue	14-15	71	71	255	255	0	180	77
Sky blue	12-13	068	068	245	77	64	173	0
Pale blue	10-11	063	063	122	0	112	127	0
Lavender	8-9	058	058	165	186	77	0	0
Bright Red	6-7	026	026	0	255	0	255	21
Med Yellow	4-5	010	010	48	0	239	115	0
Med bastard amber	2-3	004	004	0	62	78	159	0
Random Macro Color (only for Macro effects)	1	-	-	-	-	-	-	-
Unused Range	0	-	-	-	-	-	-	-

• STOP / STROBE - channel 7



BIT	EFFECT
252 - 255	OPEN
239 - 251	RANDOM FAST STROBE
226 - 238	RANDOM MEDIUM STROBE
213 - 225	RANDOM SLOW STROBE
208 - 212	OPEN
207	FAST PULSATION
...	...
108	SLOW PULSATION
104 - 107	OPEN
103	FAST STROBE (12 flash/sec)
...	...
4	SLOW STROBE (1 flash/sec)
0 - 3	CLOSED

IMPORTANT: The lamp dim to half power 1 second after the channel stay at 0 bit level. The lamp goes back to full power when the channel level is put higher than 0 bit.

• DIMMER - channel 8



BIT	EFFECT
255	
...	...
0	

The lamp is linearly dimmed from full power to half power electronically and mechanically from half power to off.

• DIMMER FINE - channel 9



BIT	EFFECT
255	
...	...
0	

• IRIS - channel 10



BIT	EFFECT
252 - 255	MAXIMUM APERTURE
251	FAST PULSATION, FAST CLOSING
...	...
212	SLOW PULSATION, FAST CLOSING
211	FAST PULSATION, FAST OPENING
...	...
172	SLOW PULSATION, FAST OPENING
171	FAST PULSATION
...	...
132	SLOW PULSATION
128 - 131	MAXIMUM APERTURE
...	...
0	MINIMUM APERTURE

• STATIC GOBO CHANGE - channel 11

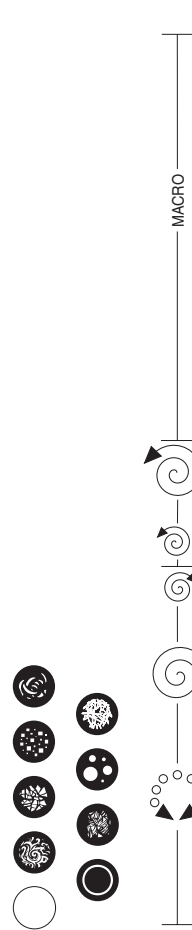

BIT	EFFECT
255	GOBO 8 SHAKE, FAST SPEED
...	...
244	GOBO 8 SHAKE, SLOW SPEED
243	GOBO 7 SHAKE, FAST SPEED
...	...
232	GOBO 7 SHAKE, SLOW SPEED
231	GOBO 6 SHAKE, FAST SPEED
...	...
220	GOBO 6 SHAKE, SLOW SPEED
219	GOBO 5 SHAKE, FAST SPEED
...	...
208	GOBO 5 SHAKE, SLOW SPEED
207	GOBO 4 SHAKE, FAST SPEED
...	...
196	GOBO 4 SHAKE, SLOW SPEED
195	GOBO 3 SHAKE, FAST SPEED
...	...
184	GOBO 3 SHAKE, SLOW SPEED
183	GOBO 2 SHAKE, FAST SPEED
...	...
172	GOBO 2 SHAKE, SLOW SPEED
171	GOBO 1 SHAKE, FAST SPEED
...	...
160	GOBO 1 SHAKE, SLOW SPEED
159	FAST ROTATION (100 rpm)
...	...
118	SLOW ROTATION (5 rpm)
114 - 117	STOP
113	SLOW ROTATION (5 rpm)
...	...
72	FAST ROTATION (100 rpm)
64 - 71	GOBO 8
56 - 63	GOBO 7
48 - 55	GOBO 6
40 - 47	GOBO 5
32 - 39	GOBO 4
24 - 31	GOBO 3
16 - 23	GOBO 2
8 - 15	GOBO 1
0 - 7	WHITE

• ROTATING GOBO CHANGE - channel 12

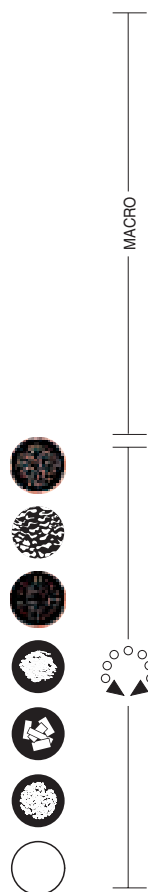

BIT	EFFECT
255	GOBO 6 SHAKE, FAST SPEED
...	...
235	GOBO 6 SHAKE, SLOW SPEED
234	GOBO 5 SHAKE, FAST SPEED
...	...
214	GOBO 5 SHAKE, SLOW SPEED
213	GOBO 4 SHAKE, FAST SPEED
...	...
193	GOBO 4 SHAKE, SLOW SPEED
192	GOBO 3 SHAKE, FAST SPEED
...	...
172	GOBO 3 SHAKE, SLOW SPEED
171	GOBO 2 SHAKE, FAST SPEED
...	...
151	GOBO 2 SHAKE, SLOW SPEED
150	GOBO 1 SHAKE, FAST SPEED
...	...
130	GOBO 1 SHAKE, SLOW SPEED
112-129	GOBO 6
...	...
93-111	GOBO 5
...	...
75-92	GOBO 4
...	...
56-74	GOBO 3
...	...
38-55	GOBO 2
...	...
19-37	GOBO 1
0-18	WHITE

• GOBO ROTATION - channel 13



BIT	EFFECT
255	FAST ROTATION (150 rpm)
193	SLOW ROTATION (2,2 rph)
191 - 192	STOP
190	SLOW ROTATION (2,2 rph)
128	FAST ROTATION (150 rpm)
127	540° POSITION
105	450° POSITION
84	360° POSITION
63	270° POSITION
42	180° POSITION
21	90° POSITION
0	0° POSITION

• GOBO FINE - channel 14



BIT
255
127
0

• PRISM INSERTION - channel 15

BIT	EFFECT
255	PRISM INSERTED
128	
127	PRISM EXCLUDED
0	

• PRISM ROTATION - channel 16



BIT	EFFECT
255	FAST ROTATION (120 rpm)
193	SLOW ROTATION (3 rph)
191 - 192	STOP
190	SLOW ROTATION (3 rph)
128	FAST ROTATION (120 rpm)
127	POSITION 540°
105	POSITION 450°
84	POSITION 360°
63	POSITION 270°
42	POSITION 180°
21	POSITION 90°
0	POSITION 0°

• FROST - channel 17



BIT	EFFECT
255	FROST INSERTED
0	FROST EXCLUDED

• BLADE UP 1 - channel: 18



BIT	EFFECT
255	BLADE IN
127	
0	BLADE OUT

• BLADE UP 2 - channel: 19



BIT	EFFECT
255	BLADE IN
127	
0	BLADE OUT

• BLADE DW 1 - channel: 20



BIT	EFFECT
255	BLADE IN
127	
0	BLADE OUT

• BLADE DW 2 - channel: 21



BIT	EFFECT
255	BLADE IN
127	
0	BLADE OUT

• BLADE LF 2 - channel: 25



BIT	EFFECT
255	BLADE IN
127	
0	BLADE OUT

Important:

The lamp automatically dim to half power in any condition in which the blades completely shut the light beam.

• BLADE RG 1 - channel: 22



BIT	EFFECT
255	BLADE IN
127	
0	BLADE OUT

• FRAMING ROTATION - channel: 26



BIT	EFFECT
255	
127	
0	

• BLADE RG 2 - channel: 23



BIT	EFFECT
255	BLADE IN
127	
0	BLADE OUT

• FOCUS - channel 27



BIT	EFFECT
255	NEAR
0	DISTANT

• BLADE LF 1 - channel: 24



BIT	EFFECT
255	BLADE IN
127	
0	BLADE OUT

• FOCUS FINE - channel 28



BIT	EFFECT
255	NEAR
0	DISTANT

• ZOOM - channel: 29



BIT	EFFECT
255	NARROW BEAM
0	WIDE BEAM

• AUTOFOCUS DISTANCE - channel 30

AUTOFOCUS priority:

- 1 - Blades
- 2 - Rotating Gobo
- 3 - Static Gobo
- 4 - Iris

BIT	EFFECT
255	100 METRES
128	50 METRES
102	40 METRES
77	30 METRES
51	20 METRES
26	10 METRES
7	3 METRES
0-6	AUTOFOCUS OFF

• AUTOFOCUS ADJUSTMENT - channel 31

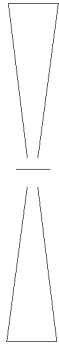

BIT	EFFECT
255	FOCUS FINE
128	
0	FOCUS FINE

• MACRO EFFECTS - channel 32

BIT	EFFECT
232-255	STAND BY BLACK
220-231	RANDOM MACRO 8
208-219	RANDOM MACRO 7
196-207	RANDOM MACRO 6
184-195	RANDOM MACRO 5
172-183	RANDOM MACRO 4
160-171	RANDOM MACRO 3
148-159	RANDOM MACRO 2
136-147	RANDOM MACRO 1
112-135	STAND BY BLACK
100-111	MACRO 8
88-99	MACRO 7
76-87	MACRO 6
64-75	MACRO 5
52-63	MACRO 4
40-51	MACRO 3
28-39	MACRO 2
16-27	MACRO 1
12-15	STAND BY BLACK
8-11	STAND BY
0-7	MACRO OFF

• PAN - channel 33

Operation with option InvertPan \diamond Off
(Tilt conventionally represented at 35 bit and option Invert Tilt \diamond Off)

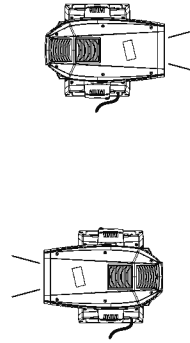

BIT
255
0

Operation with option InvertPan \diamond On
(Tilt conventionally represented at 35 bit and option Invert Tilt \diamond Off)

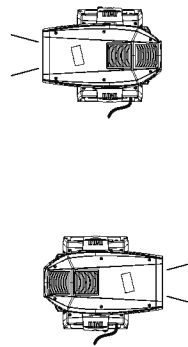

BIT
255
0

• PAN FINE - channel 34

Operation with option InvertPan \diamond Off
(Tilt conventionally represented at 35 bit and option Invert Tilt \diamond Off)

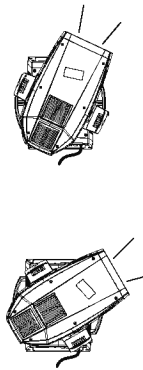

BIT
255
0

Operation with option InvertPan \diamond On
(Tilt conventionally represented at 35 bit and option Invert Tilt \diamond Off)

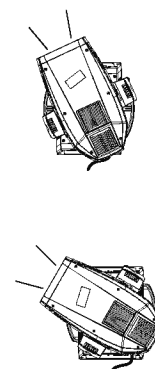

BIT
255
0

• **TILT - channel 35**

Operation with option Invert Tilt \diamond Off
 (Pan conventionally represented at 0 bit and option Invert Pan \diamond Off)

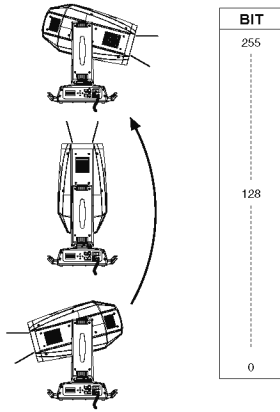

Operation with option Invert Tilt \diamond On
 (Pan conventionally represented at 0 bit and option Invert Pan \diamond Off)

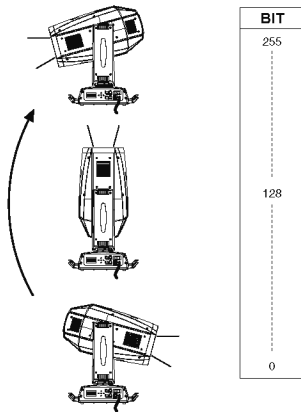

• **TILT FINE - channel 36**

Operation with option Invert Tilt \diamond Off
 (Pan conventionally represented at 0 bit and option Invert Pan \diamond Off)

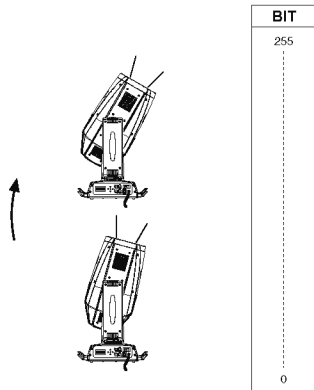

Operation with option Invert Tilt \diamond On
 (Pan conventionally represented at 0 bit and option Invert Pan \diamond Off)

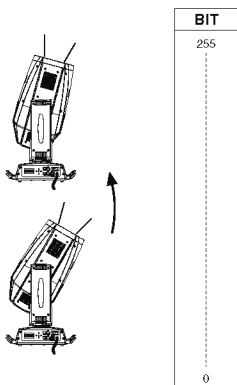

• **FUNCTION - channel: 37**

BIT	EFFECT	
255	UNUSED RANGE	
63		
51-62		DIMMER CURVE FUNCTION
38-50		
25-37		PAN-TILT FUNCTION
12-24	FAST (Default)	
0-11	UNUSED RANGE	

The functions are activated passing through unused range and staying 5 seconds in necessary level.

• **RESET - channel: 38**

BIT	EFFECT
255	COMPLETE RESET
...	Complete reset is activated passing through the unused range and staying 5 seconds in complete reset levels.
128	COMPLETE RESET
127	PAN / TILT RESET
...	Pan / Tilt reset is activated passing through the unused range and staying 5 seconds in Pan / Tilt reset levels.
77	PAN / TILT RESET
76	EFFECTS RESET
...	Effects reset is activated passing through the unused range and staying 5 seconds in Effects reset levels.
26	EFFECTS RESET
25	...
0	UNUSED RANGE

The functions are activated passing through unused range and staying 5 seconds in necessary level.

• **LAMP CONTROL (only with option LAMP DMX On) - channel: 39**

IMPORTANT: Alpha Profile 1500 is not provided with hot restrike igniter

BIT	EFFECT
255	LAMP ON (1500W)
...	Lamp ignition after 5 s in full power levels. Immediate transition from half to full power.
180	LAMP ON (1500W)
179	LAMP ON (1200W)
...	Immediate transition from full to half power. Lamp ignition not allowed in half power.
101	LAMP ON (1200W)
100	LAMP OFF
...	Lamp switch off passing through the unused range and staying 5 s in Lamp OFF levels.
26	LAMP OFF
25	...
0	UNUSED RANGE

The functions are activated passing through unused range and staying 5 seconds in necessary level.

TIMING CHANNELS

	Timing Channel	Channel function
40	Pan - Tilt time	Pan – Tilt – Pan Fine – Tilt Fine
41	Colour time	Cyan - Magenta - Yellow – C.T.O. – Color wheel
42	Beam time	Dimmer – Zoom – Focus – Frost/Prism – Iris - Framing Rotation
43	Gobo time	Fix Gobo –Rotating Gobo change

TIME TABLE

BIT	Seconds	BIT	Seconds	BIT	Seconds	BIT	Seconds	BIT	Seconds	BIT	Seconds
0	Full	43	8.6	86		129		172		216	
1	0.2	44	8.8	87	24	130	41	173	58	217	170
2	0.4	45	9	88		131		174		218	
3	0.6	46	9.2	89	25	132	42	175	59	219	180
4	0.8	47	9.4	90		133		176		220	
5	1	48	9.6	91	26	134	43	177	60	221	190
6	1.2	49	9.8	92		135		178		222	
7	1.4	50	10	93	27	136	44	179	65	223	200
8	1.6	51	10.2	94		137		180		224	
9	1.8	52	10.4	95	28	138	45	181	70	225	210
10	2	53	10.6	96		139		182		226	
11	2.2	54	11	97	29	140	46	183	75	227	220
12	2.4	55	12	98		141		184		228	
13	2.6	56	13	99	30	142	47	185	80	229	230
14	2.8	57	14	100		143		186		230	
15	3	58	15	101	31	144	48	187	85	231	240
16	3.2	59	16	102		145		188		232	
17	3.4	60	17	103	32	146	49	189	90	233	250
18	3.6	61	18	104		147		190		234	
19	3.8	62	19	105	33	148	50	191	95	235	260
20	4	63	20	106		149		192		236	
21	4.2	64	21	107	34	150	51	193	100	237	270
22	4.4	65	22	108		151		194		238	
23	4.6	66	23	109	35	152	52	195	110	239	280
24	4.8	67	24	110		153		196		240	
25	5	68	25	111	36	154	53	197	120	241	290
26	5.2	69	26	112		155		198		242	
27	5.4	70	27	113	37	156	54	199	130	243	300
28	5.6	71	28	114		157		200		244	
29	5.8	72	29	115	38	158	55	201	140	245	310
30	6	73	30	116		159		202		246	
31	6.2	74	31	117	39	160	56	203	150	247	320
32	6.4	75	32	118		161		204		248	
33	6.6	76	33	119	40	162	57	205	160	249	330
34	6.8	77	34	120		163		206		250	
35	7	78	35	121	41	164	58	207	170	251	340
36	7.2	79	36	122		165		208		252	
37	7.4	80	37	123	42	166	59	209	180	253	350
38	7.6	81	38	124		167		210		254	
39	7.8	82	39	125	43	168	60	211	190	255	360
40	8	83	40	126		169		212			
41	8.2	84	41	127	44	170	61	213	200		
42	8.4	85	42	128		171		214			
								215			